

AUTOMATIC CABLE MARKING SYSTEM

USER MANUAL

P/N ACMU6A01



Section 1	Description
	1.1 System Description
	1.2 General Operation
	1.3 Accuracy
	1.4 Calibration
Section 2	Installation
	2.1 Measuring Arm
	2.2 Control Panel
	2.3 Preliminary Test
Section 3	Operation
	3.1 Software Instructions – Main Screen
	3.2 Software Instructions – Menu
	3.3 Software Instructions – Mark Reset
	3.4 Marking the Cable
	3.5 Variations of Marking
	3.6 General Comments on Markings
	3.7 Metric System
Section 4	Troubleshooting
Section 5	Features and Specifications
	5.1. Size and Weight specifications
	5.2 Wiring Diagram
	5.3 Checking / Replacing Fuses
	5.4 Checking Minor Marker / Detector Polarity
	5.5 Reversing Magnetic Mark Polarity
	5.6 Recommended Spare Parts
	5.7 Panel Layout Diagram
Section 6	Electrical Diagrams, Schematics, Parts Lists
Section 7	New Software Installation
Section 8	Principals of Magnetic Marking

Section 1 – Description

1.1 System Description

The Automatic Cable Marking Unit (ACMU) will measure and place magnetic marks on a cable at 25 meter, 50 meter or 100 ft. intervals with an accuracy of 0.01% (or .3 m in 3000 m, - 1 ft. in 10,000) when operated on a cable at a constant tension and line speeds between 15 and 185 m per minute (50 and 600 ft. per minute).

The ACMU is designed to be used in field service locations to measure and mark a cable as it is spooled under constant tension between two winches. With proper set-up, two men familiar with the ACMU can easily re-calibrate and mark 4500 m (15,000 ft.) of cable in one hour.

The operating principal ⁽¹⁾ of this unit is similar to that of hand marking a cable. The basic differences are that the ACMU uses a very sharp magnetic mark in place of a pencil or chalk to mark the interval and the interval (or base length) used in the ACMU is 1.67 m (metric base) or 5 ft. (English base) Instead of the 50 m or 100 ft. tape used in the hand marking.

There are two basic components in the ACMU; the measuring frame and the control panel. The measuring frame contains a degaussing (erase) coil, interval marker, detector, and major marker.



This system replaces the current Kerr ACMU1A01 marking panel. It is compatible with the existing Kerr ACMU2A01, ACMU3A01, and ACMU4A01 marking arms and frame assembly.

A typical system consists of the following items.

Parent Item Number: ACMU6A10 KIT ACMU TOUCH SCREEN SYSTEM

Component	Description	Qty Required
ACMU6A01	PANEL ASSY ACMU TOUCH SCREEN	1
ACMU6A02	PANEL ASSY ERASE TRANSFORMER	1
ACMU2A11	ACMU FRAME ASSY	1
ACMU3A31	ENGLISH MEASUREMENT BASE ASSY	1
ACMU4A31	METRIC MEASUREMENT BASE ASSY	1
ACMU1A11-30	CABLE ASSY ACMU UMBILICAL 30FT	1
AMS6A001	HAND MARK LOCATR (GAUSS METER)	1
ACMU1A11-05	CABLE ASSY ACMU UMBILICAL 5FT	1
ACMU6P13	LOAD CELL 13,000 LB 2mV/V LINK	OPTIONAL
AM1KA110	DEVICE CABLE MSRMT 2FT TANGENT	OPTIONAL

The control panel contains an industrial PC running MS-Windows. The PC input is accomplished by either using the touch screen placed over the display or through a keyboard that is provided.



A PC scope card is used to display the minor mark signals. This scope card replaces the conventional oscilloscope used in the old panels. The control panel provides signal to threshold adjustment and both visual and audible indication of

interval marking and the major magnetic mark every 25 or 50 m with metric base or 100 ft. with English base.

The panel includes encoder and tension inputs to allow the system to display, record and print depth, tension, and mark data. An intercom system is also included. The intercom provides a means to connect a remote speaker which can be used for voice communication.

A connection to an internal relay is provided to allow an external high volume alarm to be used so major marks can be heard in a noisy environment.

The system is packaged inside a Hardigg ProRack double lid case.

The Erase transformer and Variac are removed from the control panel and packaged in a separate enclosure. This allows the de-gausser to be operated independently from the control panel. It can also be connected through the panel so marks can be erased while the cable is being marked.



The ACMU comes with a 9 m (30 ft.) umbilical cable and is wired “pin to pin”, allowing either end of the umbilical cable to be attached to the control cable. A

1.5m (5 ft.) cable is also included to connect the erase panel to the rear of the control panel.

The panel will operate on 115 volts, 60 hertz or 220 volts, 50 or 60 hertz as ordered. The grounding system for the unit is through the power cord and a 3-prong male connector is provided. It is very important that the power source has a good proper earth ground.

FIGURE 1 – ACMU SYSTEM

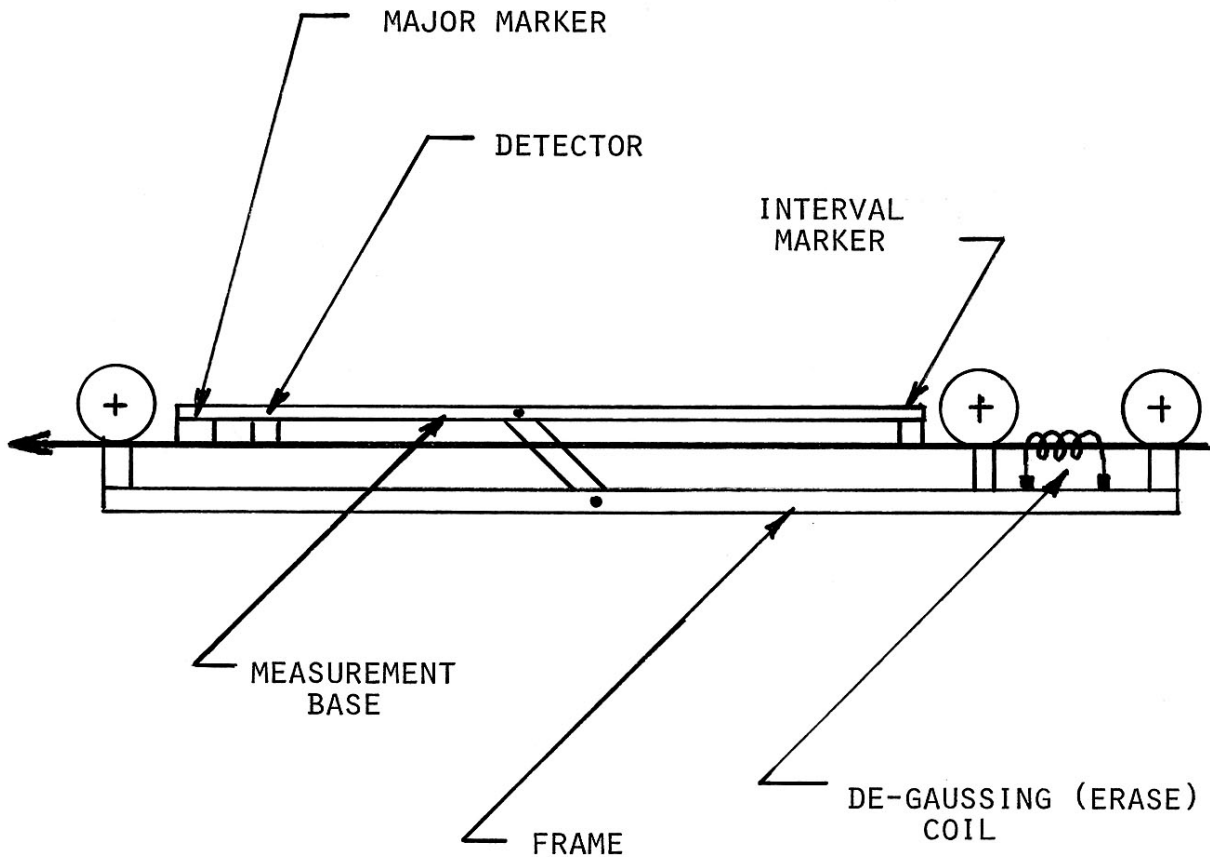

1.2 General Operation

The spooling equipment must be set-up to maintain a constant tension over the desired line speed range. This reference tension is usually 450 kg (1000 pounds). With this prerequisite, the system operates as follows:

1. With the cable stopped, the initial reference mark and the first major mark are applied to the cable. The momentary switch on the control panel also resets the counter.
2. As the cable enters the measuring frame, the degaussing coil magnetically cleans it.
3. With the cable in motion, the reference mark moves the base length and activates the detector. The length of the English base is 5 ft. and the length of the metric base is 1.6667 m.
4. The signal from the detector is displayed on the panel, crosses a displayed threshold line, begins the counter and triggers the reference marker, placing a new reference mark on the cable 1.6667 m (Metric base) or 5 ft. (English base) behind the previous reference mark.
5. This process continues as long as the cable is in motion. At the count of twenty (20), a major magnetic mark is applied 100 ft. behind the previous one and the counter is reset. For 25 m marks, a count of fifteen (15) is used. For 50 m marks, thirty (30) minor marks are used.

1.3 Accuracy

The accuracy of the ACMU system is .01% or .3 m in 3000 m (1 ft in 10,000 ft). This, of course, assumes that the cable under measurement does not change length during the marking operation.

Proper set-up of the cable spooling arrangement cannot be over emphasized. Accurate measurement and marking demands a constant tension to eliminate changes in cable length due to the cables' inherent stretch characteristics.

Typical 7 conductor logging cables have an elastic stretch coefficient of .25 -.27 m / 300 m / 450 kg (0.8-0.9 ft. / 1000 ft. / 1000 pounds). In addition, new cables can have an in-elastic (permanent) stretch of up to 0.2% or 6 m in 3000 m (20 ft. in 10,000 ft.) before they are "seasoned".

Using the elastic stretch characteristics only, it is easy to see that a 225 kg (500 pound) variation in tension during marking could result in a possible error of 1.2-

1.3 m in 3000 m (4 - 4.5 feet in 10,000). A good set-up should hold the reference tension (usually 450 kg or 1000 pounds) constant within + or – 2 ½%.

1.4 Calibration

The base (reference) distance is calibrated to a standard traceable to the bureau of standards. The base frame is chosen to match the thermal coefficient of expansion of most logging cables at 450 kg (1000 pounds) tension.

In order to maintain the highest degree of accuracy possible with the ACMU, authorized personnel only will perform field calibration. An error of only .4 mm in calibration of the 1.67 m base length will result in an error of almost 1 m in 3000m. An error of 1/64” in calibration of the 5 ft. base length will result in an error of almost 3 ft. in 10,000.

Section 2 – Installation

2.1 Measuring Arm

The measuring arm consists of two basic components: the frame with support rollers and the top measurement base which rides upon the cable. This system does not enclose the cable and can be installed from the side.

Each end of the frame will accept a universal joint retaining arm system for versatility of installation.

Care must be taken to locate the measuring arm in the cable path where bouncing and erratic cable motion is at a minimum.

Keeping in mind that the cable must move through the ACMU from the degaussing coil to the major mark end, the sequence of installation is:

1. Set the frame onto the cable, making sure that the cable rides in the three grooved wheels.
2. Position the hinged measurement base on the cable, ensuring that the cable rides smoothly in the three grooves of the internal marker, detector, and major marker.

FIGURE 2 – COIL INSTALLATION

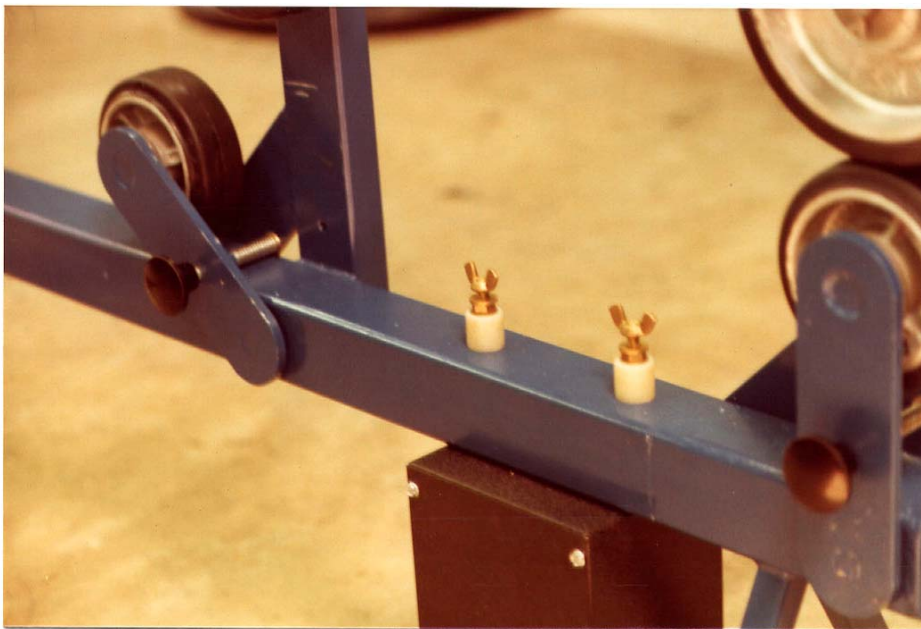
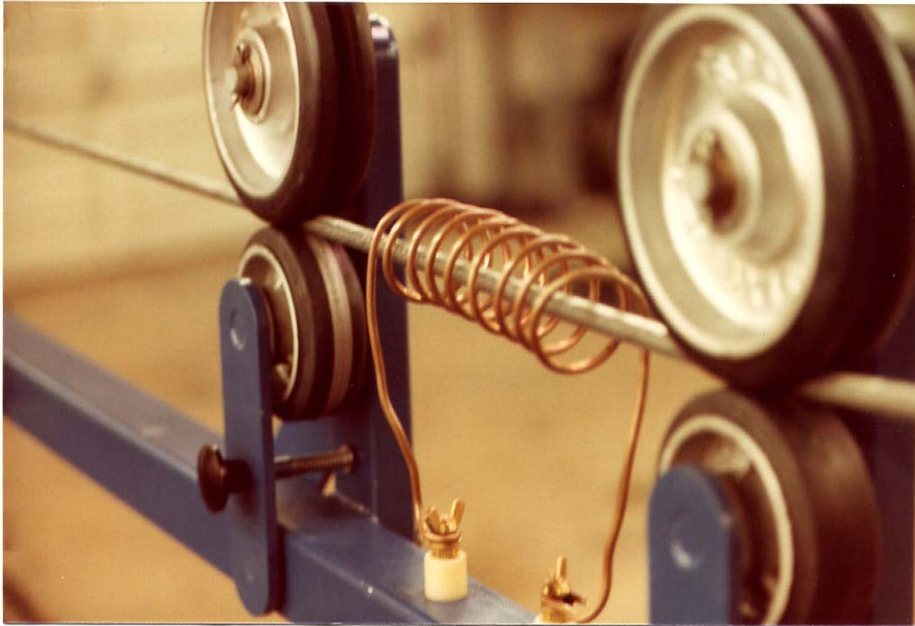
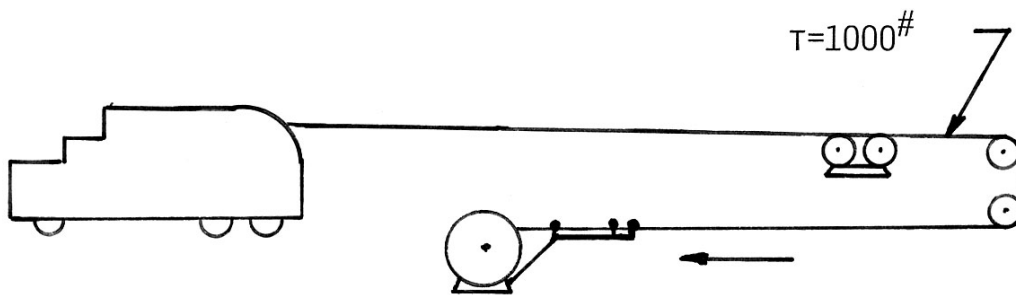
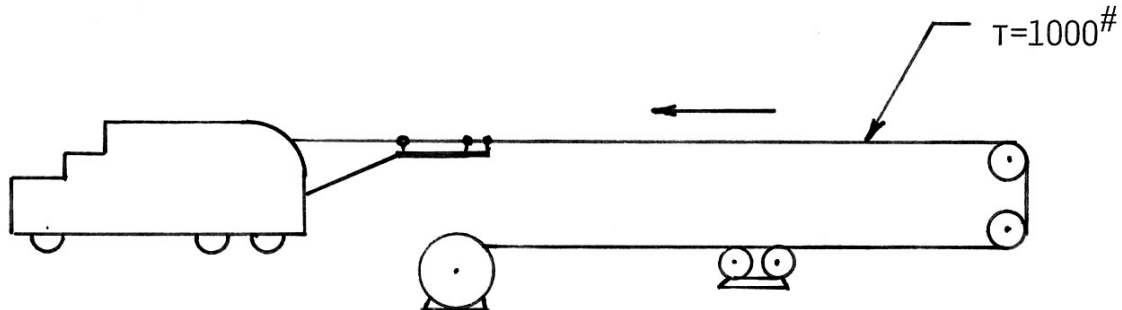

FIGURE 3 – TYPICAL INSTALLATION



3. Move the three retaining wheels into position immediately below the three grooved wheels and make sure that the spring loaded locks are in place.
4. Move the frame along the cable to a convenient location and attach the retaining arm with universal joint system onto (as preferred) the:
 - A. Breaking Capstan
 - B. Truck Bumper
 - C. Garage Winch
5. The erase coil is then spiraled around the cable and firmly attached with “wing nuts” to the two erase terminals.

6. Remove the dust cap and attach one end of the umbilical cable to the measurement frame via the fourteen contact connector.

2.2 Preliminary Test

1. Plug the unit into a well-grounded power source.
2. Turn the erase potentiometer to 0.
3. Turn on the operating switch and allow 30 seconds for the unit to warm up.
4. When the power switch is turned on, an audible “beep” occurs for 1 to 3 seconds.
5. Two horizontal lines should appear on the CRT.
6. Adjust the intensity and focus controls for proper display on the CRT.
7. Turn the erase potentiometer control up to 50 on the dial and note that the current indicating light becomes brighter as it approaches 50.
8. Push the momentary reset and manual mark switch and note that the counting indicator lights return to “0”. The red “0” light should remain on. Both meters should indicate a momentary voltage reduction indicating continuity to the markers.
9. Turn the erase potentiometer to 0 and turn off the unit.
10. The unit is ready for marking cable.
11. During this test, a major magnetic mark has been placed on the cable (step no. 8). If the measurement arm has not been placed at the desired starting point, this mark must be removed by passing it through the erase coil.

Section 3 – Operation

3.1 Panel Software – Main Screen

When the system first boots up, the main screen will appear.

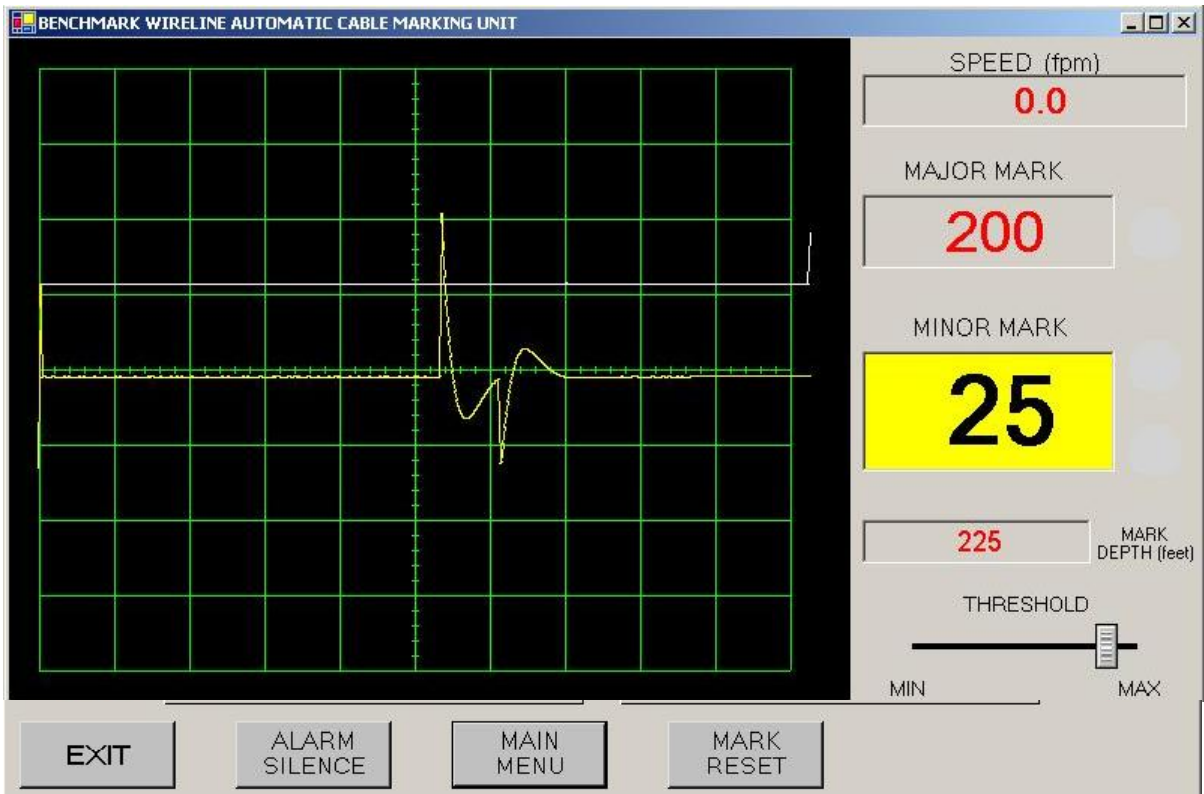

Most of the commands are accessed through the buttons across the bottom of the screen.

EXIT: Will close this program

THRESHOLD: This slider will move the threshold trace which is visible on this main screen. The proper setting of this threshold level is critical to the marking job.

THRESHOLD
CORRECT

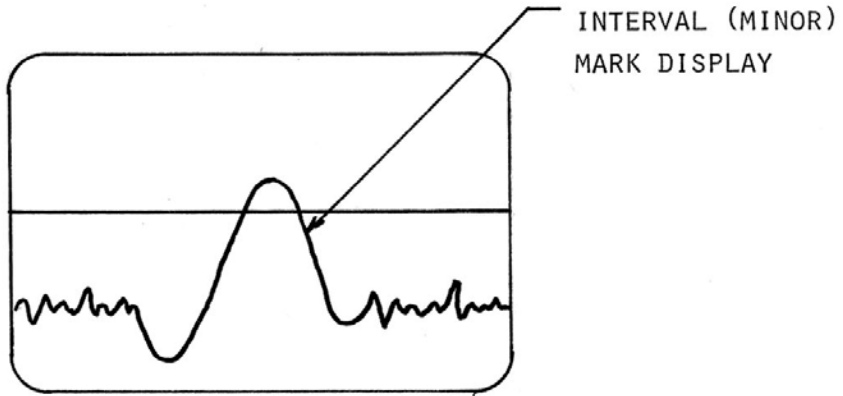

THRESHOLD
TOO HIGH

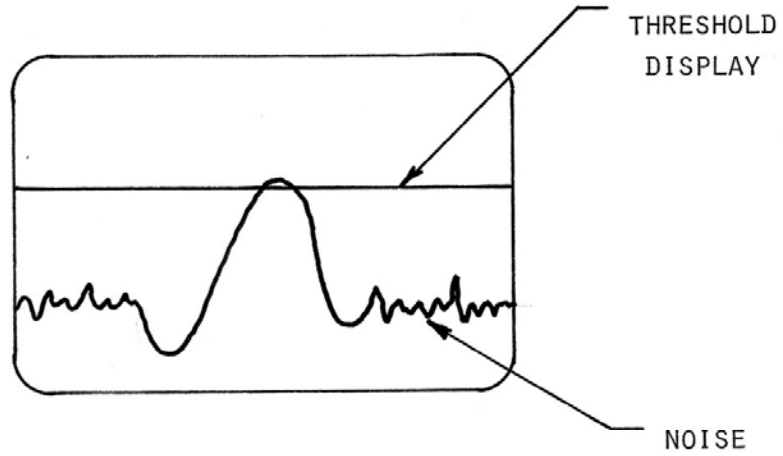

THRESHOLD
TOO LOW

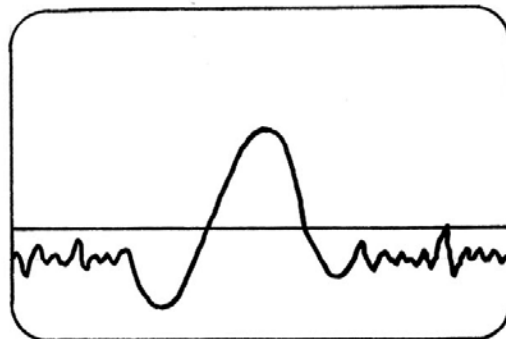

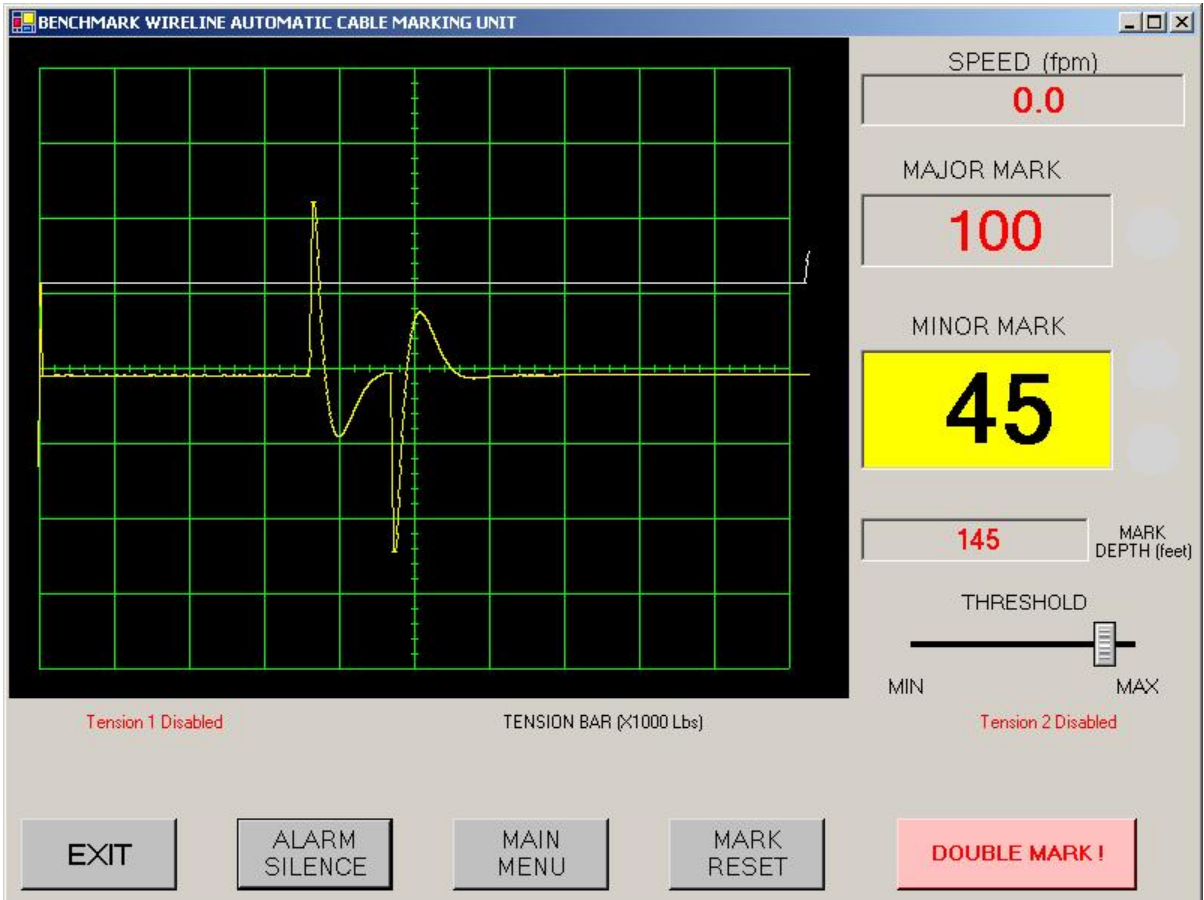

Shown above is the main menu with the Double Mark error condition.

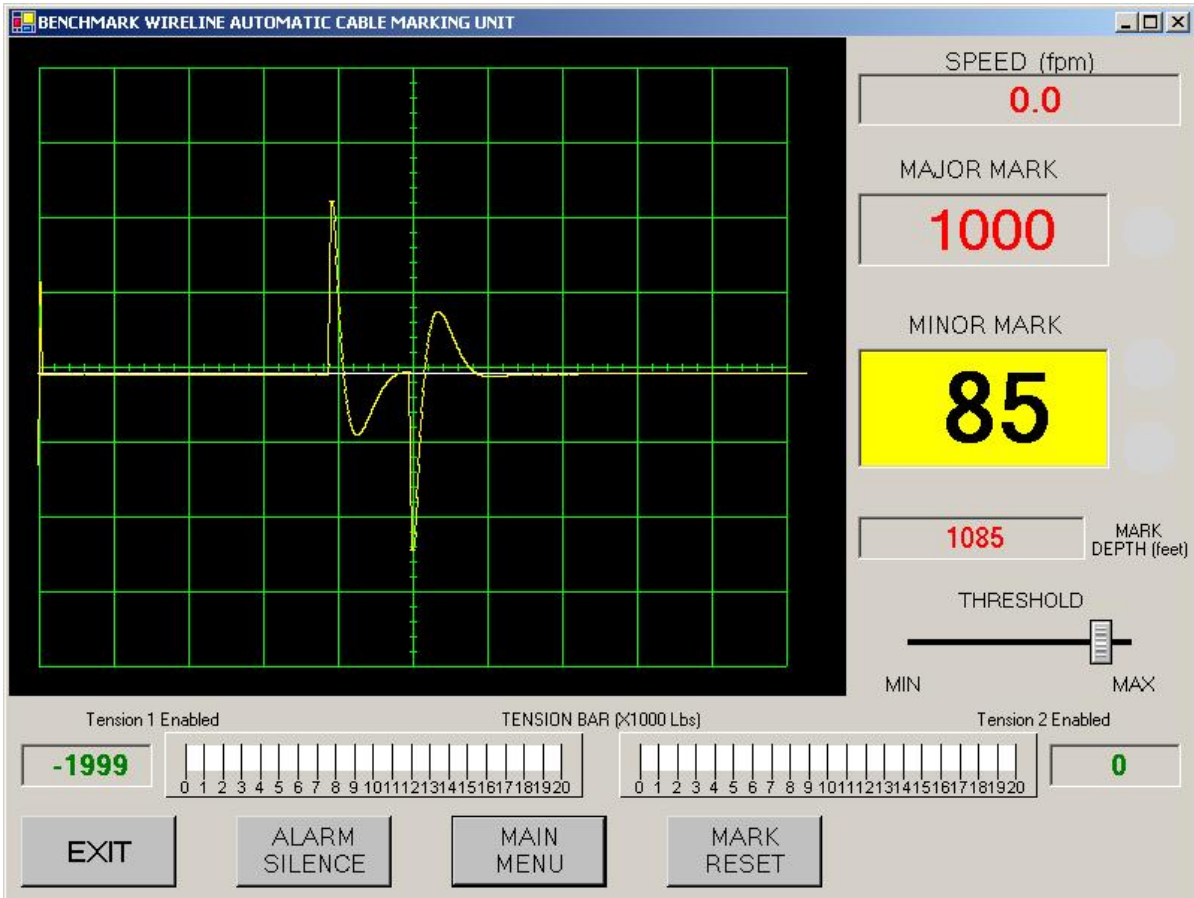

Shown above is the main screen with both Tension 1 and 2 enabled.

The ALARM SILENCE option on the main screen allows for a quick way to silence both alarms. The alarms will sound again when a new alarm condition occurs.

3.2 MAIN MENU

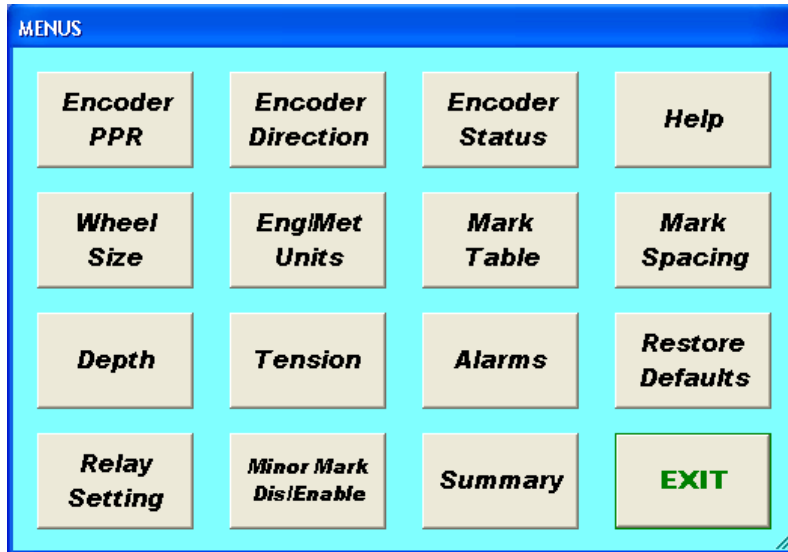

Following are the functional descriptions of each of the buttons.

3.2.1 ENCODER PPR

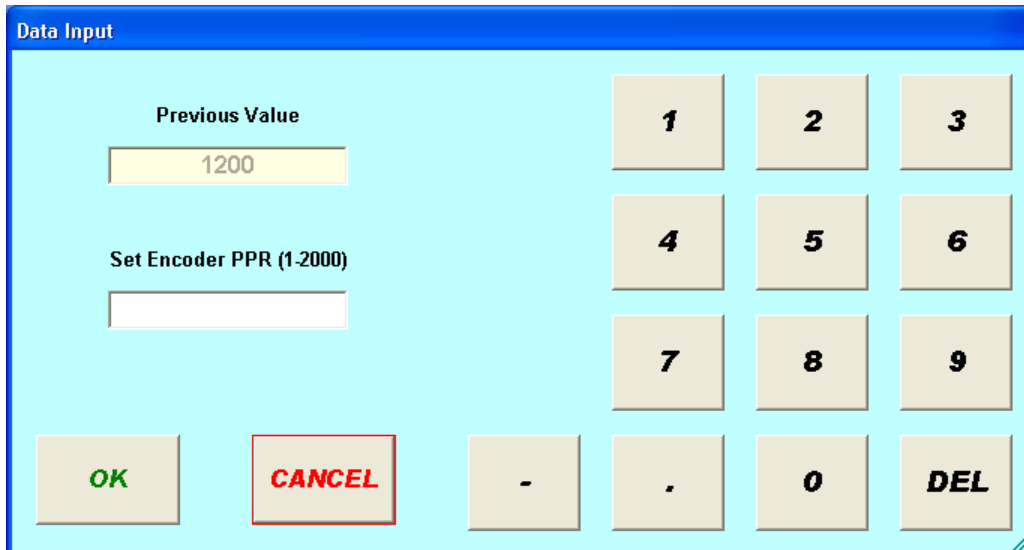

The Set Encoder PPR entry screen will appear.
The range is 1-2000

The screen allows you to set the encoder pulses per revolution setting. This number should be printed on the encoder label.

Note: The pulses per foot/meter are not set by this screen, only the encoder input. Pulses per foot/meter are calculated from encoder PPR and Wheel Size. This option is meaningful only if utilizing an encoder for depth measurement.

Default is 1200 PPR

3.2.2 ENCODER DIRECTION

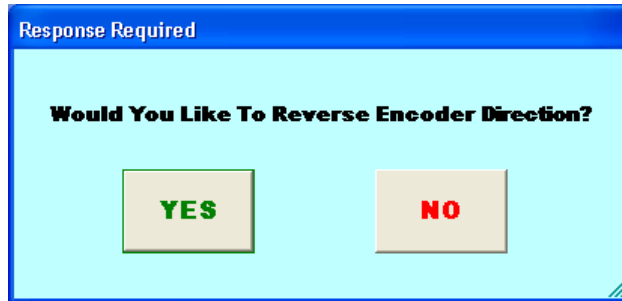

This screen allows you to change the direction of the encoder. If the depth is changing in the opposite direction to which the line is moving, this option can be used to correct it. On a dual wheel measuring device with two encoders, the encoder on one of the wheels will turn in the opposite direction from the other. If you change encoders, this feature can be used to change the encoder direction.

Note: This option is only meaningful if an encoder is utilized for depth measurement.

3.2.3 ENCODER STATUS

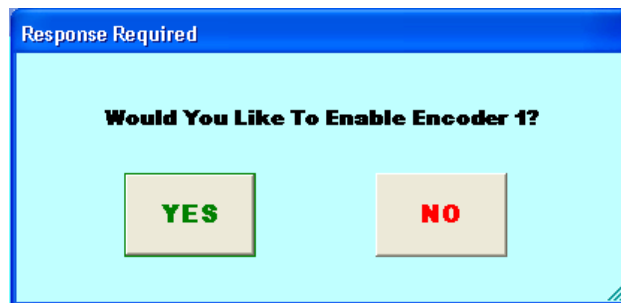
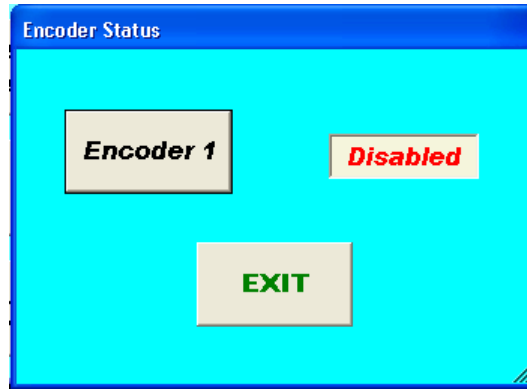

This option is only meaningful if an encoder is connected to the panel. The encoder resolution must be specified correctly and the wheel size and, optionally shim, must be known accurately to ensure proper depth operation.

3.2.4 HELP

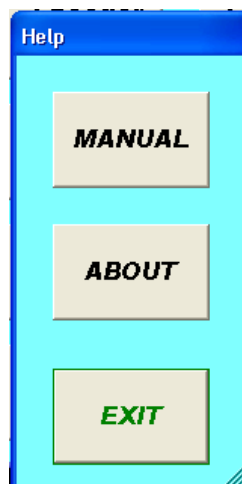

The HELP button will display the three options displayed above.

3.2.4.1 **MANUAL**

The HELP button will bring up this manual in pdf format. You can scroll up or down to find the information you need.

Note: The manual .pdf file must reside on the panel's internal C: drive in the root directory to be found by this program.

3.2.4.2 **ABOUT**

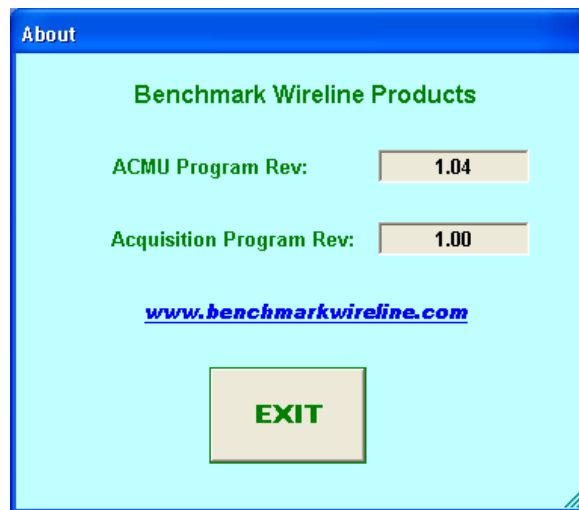

The ABOUT button displays the software revisions.

Note: If the acquisition program rev shows 1.00 as shown above – this is an error condition – re-start the panel and ensure that the acquisition program rev is higher than 1.00.

3.2.5 WHEEL SIZE



The screenshot shows a software interface titled "Data Input". It features a light blue background. On the left side, there is a "Previous Value" label above a text box containing "2.0000". Below this is a "Wheel Range: .3 - 10.0 Ft" label above an empty text box. On the right side, there is a numeric keypad with buttons for digits 1 through 9, 0, a decimal point, and a "DEL" key. At the bottom left, there are "OK" and "CANCEL" buttons. At the bottom center, there is a minus sign button. The "CANCEL" button is highlighted with a red border.

The Set Wheel Range entry screen will appear.
 The range is .3-10.0 Ft.

This setting allows you to change the size of the depth measuring wheel that is used to measure depth. To use a different measuring head from the Benchmark head, this setting will need to be changed to match the wheel size of the new head.

Default value is 2.0.

Note: This option is meaningful when utilizing an encoder for depth measurement. Wheel size and shim must be very accurate for the encoder depth to be accurate.

3.2.6 ENGLISH/METRIC UNITS

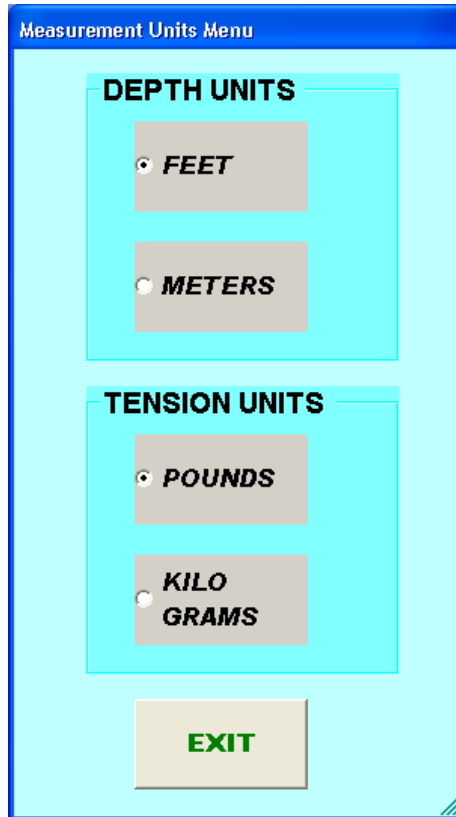

This menu allows you to select the display units for either depth or tension. Default is feet and lbs.

Note: It is recommended to change these only before a job and not during the middle of a job.

3.2.7 MARK TABLE

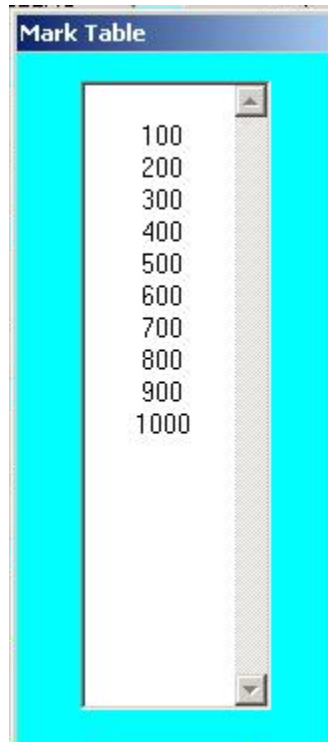

Displays the major mark depths since the last time reset marks was performed or the program was invoked.

3.2.8 MARK SPACING

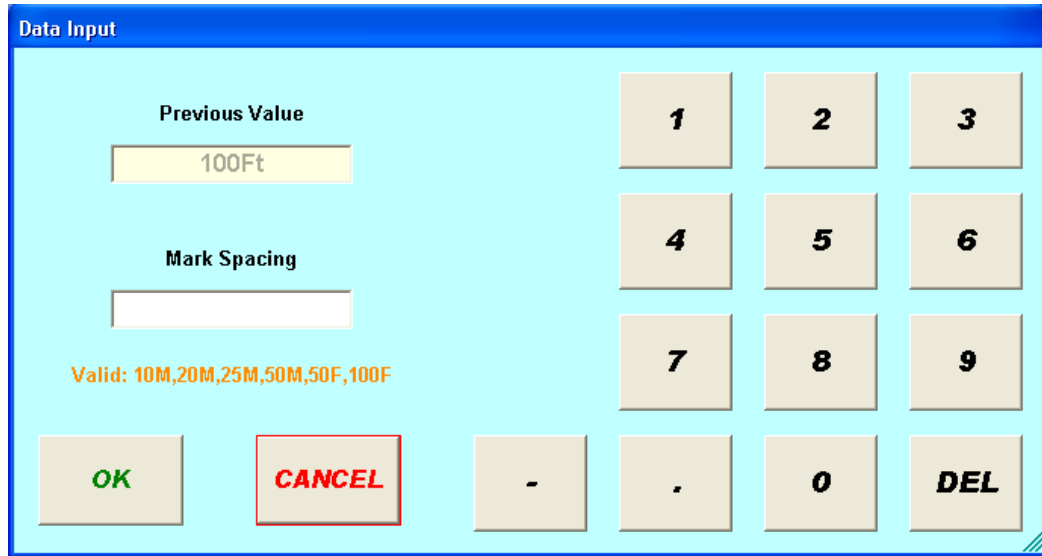

Data Input

Previous Value
100Ft

Mark Spacing

Valid: 10M,20M,25M,50M,50F,100F

OK CANCEL - . 0 DEL

The Mark Spacing entry screen will appear.
 The valid inputs include 10M, 20M, 25M, 50M, 50F, and 100F.

Note: To utilize 10M, 20M, 25M, or 50M, the panel must be set to Metric mode. To utilize 50 FT or 100 Ft the panel must to set to English mode.

3.2.9 DEPTH

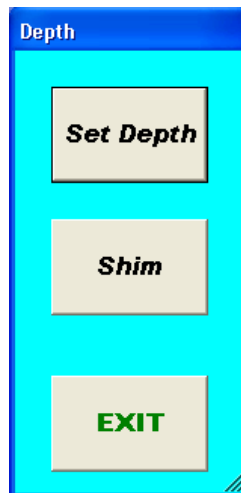

Depth

Set Depth

Shim

EXIT

3.2.9.1 SET DEPTH

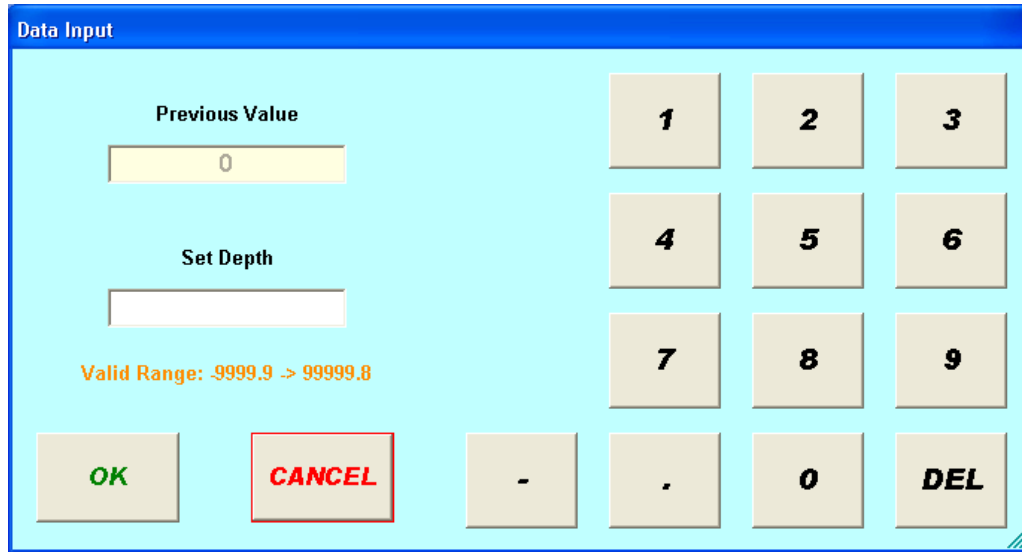

Data Input

Previous Value
0

Set Depth

Valid Range: -9999.9 -> 99999.8

OK CANCEL - . 0 DEL

The Set Depth entry screen will appear.
 The range is 9999.9 → 99999.8 feet or -3048 → 30480 meters.

Note: This option is meaningful if, for example, this panel was started in the middle of a job where a known length of line has already been spooled.

3.2.9.2 SHIM



The screenshot shows a 'Data Input' window with a light blue background. On the left, there are two input fields: 'Previous Value' containing '0.00' and 'Set Depth Shim' which is empty. Below the 'Set Depth Shim' field, the text 'Range: -10.00 - 10.00 ft/Kft' is displayed. On the right side, there is a numeric keypad with buttons for digits 1 through 9, 0, a decimal point, and a 'DEL' key. At the bottom left, there are three buttons: 'OK' (green text), 'CANCEL' (red text), and a minus sign (-).

The Set Depth Shim entry screen will appear.
 The range is 10.00 → 10.00 ft/Kft or -10 → 10 Mt/KMT.

Adds or subtracts depth continually.
 If 1 is entered then 1 foot or 1 meter will be added every 1000 feet or 1000 meters.

If -.2 is entered then .2 feet or .2 meters will be subtracted every 1000 feet or 1000 meters.

Default is 0.0

Note: This option is meaningful only if an encoder is utilized for depth and if the option is enabled.

An example for its use is if the encoder wheel is known to be over/under sized.

3.2.10 TENSION

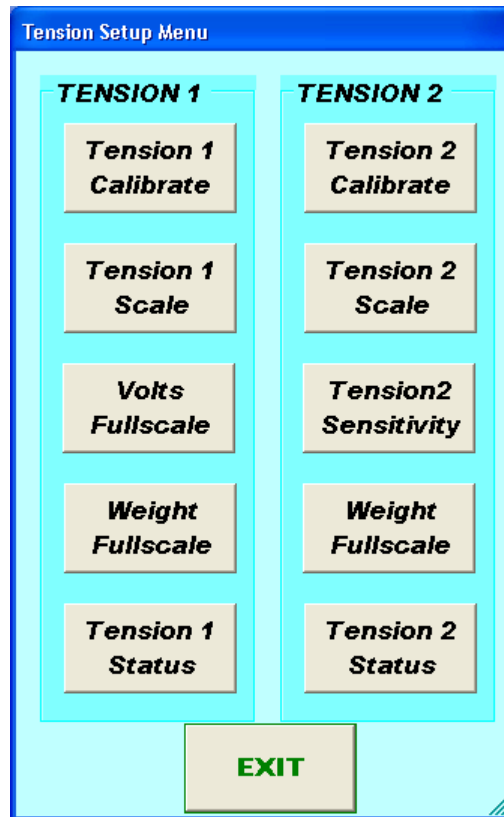

The Tension Setup Menu will appear. Following are functional descriptions of each button:

Tension 1 / 2 Calibrate refer to section 3.2.10.1

Tension 1 / 2 Scale refer to section 3.2.10.2

Tension 1 Volts Fullscale refer to section 3.2.10.3

Tension 2 Sensitivity refer to section 3.2.10.4

Weight Fullscale refer to section 3.2.10.5

Tension 1 Status refer to section 3.2.10.6

Tension 2 Status refer to section 3.2.10.7

3.2.10.1 TENSION 1 / 2 CALIBRATE

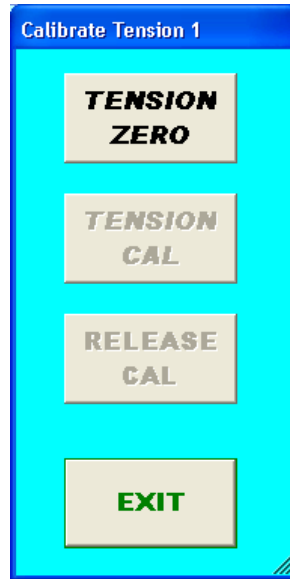

Tension zero will zero out the tension reading to establish a baseline reading.

Note: The other buttons in this menu are not available.

3.2.10.2 TENSION 1 / 2 SCALE

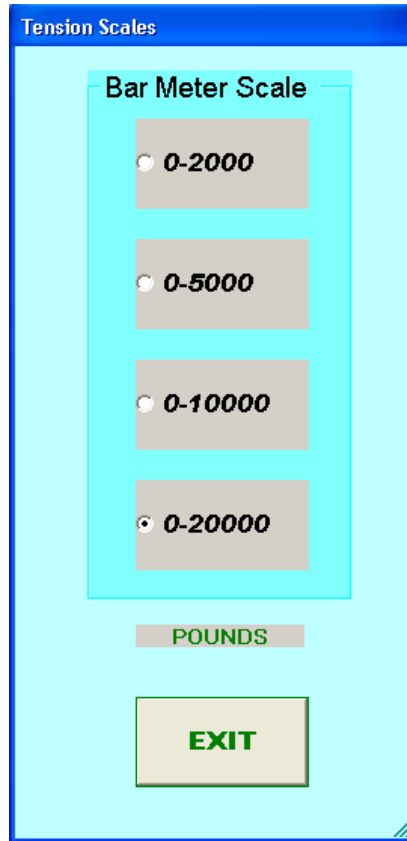

This option is only used to rescale the visual bar graph. Its setting does not affect the actual tension reading.

3.2.10.3 TENSION 1 VOLTS FULLSCALE

The screenshot shows a software interface titled "Data Input". It features two input fields on the left: "Previous Value" containing the number "4" and "Set Volts Fullscale (0.1-10.0)" which is currently empty. To the right of these fields is a numeric keypad with buttons for digits 1-9, a decimal point, a minus sign, and a "DEL" key. At the bottom left, there are "OK" and "CANCEL" buttons. The "CANCEL" button is highlighted with a red border.

The Set Volts Fullscale entry screen will appear.

This option scales the load device fullscale output.

Note: This option is for Tension 1 device only.

3.2.10.4 TENSION 2 SENSITIVITY

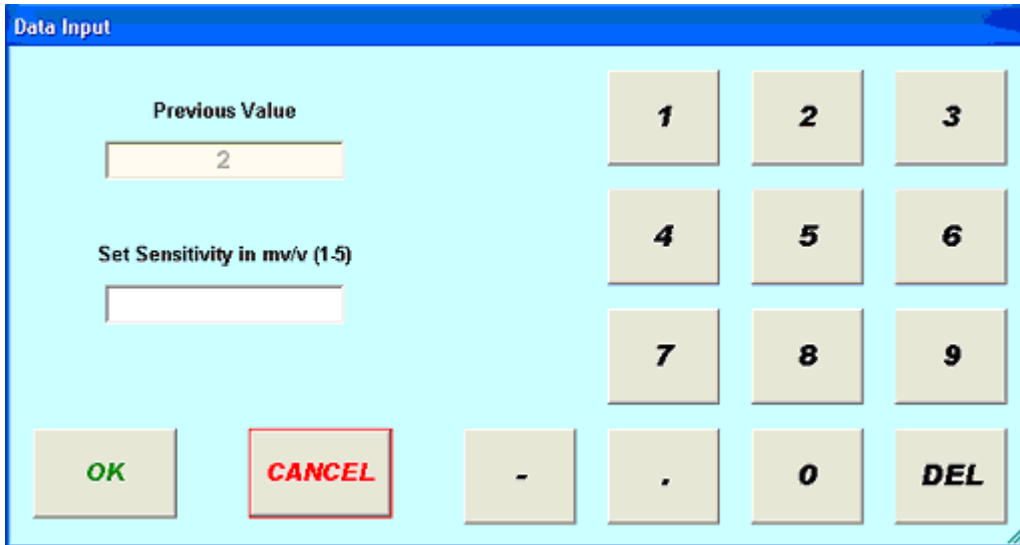

The screenshot shows a software interface titled "Data Input". It features two input fields on the left: "Previous Value" containing the number "2" and "Set Sensitivity in mv/v (1-5)" which is currently empty. To the right of these fields is a numeric keypad with buttons for digits 1 through 9, 0, a decimal point, and a "DEL" key. At the bottom of the interface are buttons for "OK", "CANCEL", "-", ".", and "0".

The Set Sensitivity in mv/v entry screen will appear.
 Note: This option is for load device 2 only. For accurate tension measurements, this setting should match the load device manufacturer's specification for sensitivity.

3.2.10.5 WEIGHT FULLSCALE 1 / 2

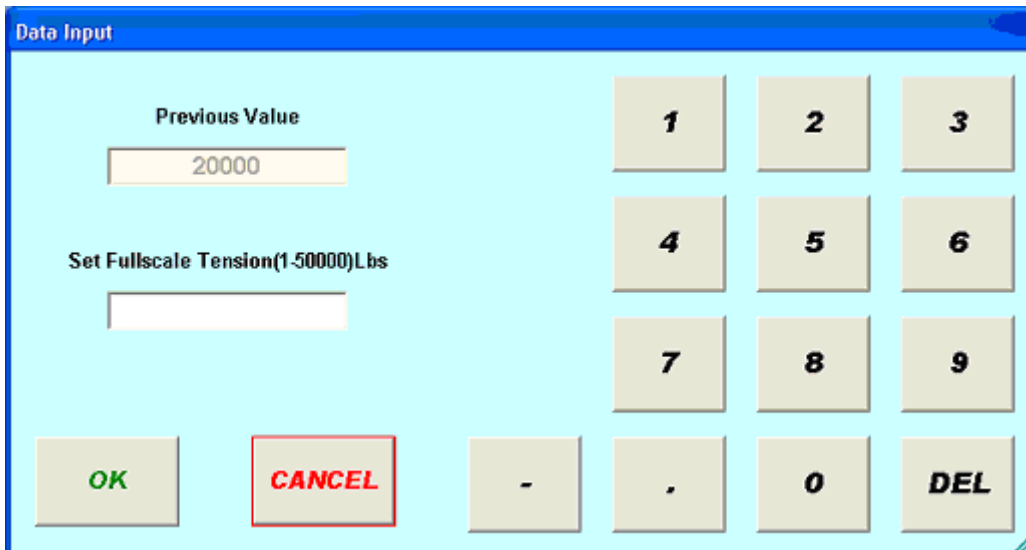

The screenshot shows a software interface titled "Data Input". It features two input fields on the left: "Previous Value" containing the number "20000" and "Set Fullscale Tension(1-50000)Lbs" which is currently empty. To the right of these fields is a numeric keypad with buttons for digits 1 through 9, 0, a decimal point, and a "DEL" key. At the bottom of the interface are buttons for "OK", "CANCEL", "-", ".", and "0".

The Set Fullscale Tension entry screen will appear.

This should match the load device manufacturer's specification for fullscale tension.

3.2.10.6 TENSION 1 STATUS

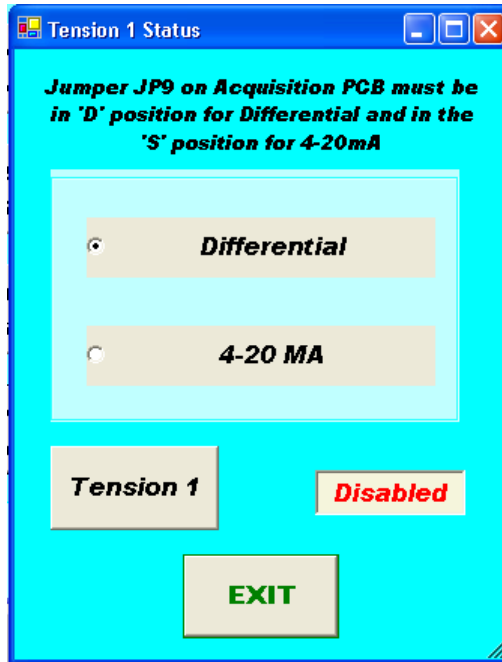

This option informs the panel software which type of load device is being utilized.

Note: The external cabling must also conform to the type of device utilized and also note the correct jumper position inside the panel.

Also note: If there is no tension device, it is recommended to set this option to: Disabled.

Default: Disabled.

3.2.10.7 TENSION 2 STATUS

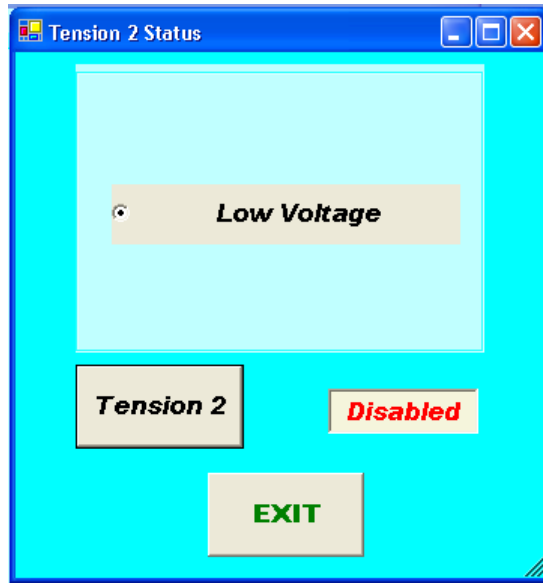

Default: Disabled

Note: If there is no tension device, it is recommended to disable this option.

3.2.11 ALARMS



Tension Alarm: refer to 3.2.11.1

Surface Alarm: refer to 3.2.11.2

Max Depth Alarm: refer to 3.2.11.3

Test Minor Mark Alarm: refer to 3.2.11.4

Minor Mark Alarm Off: refer to 3.2.11.5

Minor Mark Alarm Volume: refer to 3.2.11.6

Test Major Mark Alarm: refer to 3.2.11.7

Major Mark Alarm Off: refer to 3.2.11.8

Major Mark Alarm Volume: refer to 3.2.11.9

Test Relay: refer to 3.2.11.10

Open Relay: refer to 3.2.11.11

3.2.11.1 TENSION ALARM

The screenshot shows a software interface titled "Data Input". It features a light blue background. On the left side, there are two input fields. The first is labeled "Previous Value" and contains the number "2400". The second is labeled "Set Tension Alarm" and is currently empty. Below the second field, the text "Range: 0.1 - 19999" is displayed in orange. To the right of these fields is a numeric keypad with buttons for digits 1 through 9, 0, a decimal point, a minus sign, and a "DEL" key. At the bottom left, there are two buttons: "OK" (green text) and "CANCEL" (red text).

The Set Tension Alarm entry screen will appear.
The range is 0.1 → 19999 lbs or -1 → 9090 kgs.

Note: This alarm pertains to tension 1 device only.

3.2.11.2 SURFACE ALARM

The screenshot shows a software interface titled "Data Input". On the left side, there are two input fields. The first is labeled "Previous Value" and contains the number "100". The second is labeled "Set Surface Alarm" and is currently empty. Below these fields, the text "Range: 0 - 999 Ft" is displayed. On the right side, there is a numeric keypad with buttons for digits 1 through 9, 0, a decimal point, a minus sign, and a "DEL" key. At the bottom left, there are two buttons: "OK" and "CANCEL".

The Set Surface Alarm entry screen will appear.
The range is 0 to 999 ft or 0 to 305 meters.

When this depth value is reached, the alarm will sound warning the operator that you are approaching the surface.

Default value is 100 feet or 305 meters.

3.2.11.3 MAX DEPTH ALARM



Data Input

Previous Value
30000

Set Max Depth Alarm
[Empty Input Field]

Range: Surface Alarm - 30000 Ft

OK CANCEL - . 0 DEL

The Set Max Depth Alarm entry screen will appear. The range is from the surface alarm setting to 30,000 feet or 9144 meters.

This option allows you to enter in the maximum depth desired. If the line goes below that depth then an alarm will sound.

Default: 30,000 ft or 9144 meters.

3.2.11.4 TEST MINOR MARK ALARM



This button will sound the Minor Mark alarm. This can be used to verify the alarm is working and to determine if the volume is adequate.

3.2.11.5 MINOR MARK ALARM OFF



This button silences the Minor Mark Alarm until a new alarm condition occurs.

3.2.11.6 MINOR MARK ALARM VOLUME

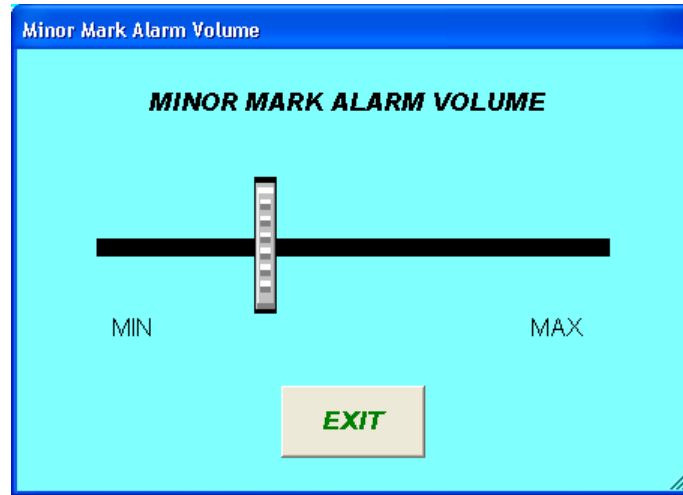

This button will bring up a slider bar which is used to adjust the Minor Mark Alarm volume. Use the "Test Alarm" button to test the volume.

Note: Typically, the minor mark alarm volume is set lower than the major mark alarm volume.

3.2.11.7 TEST MAJOR MARK ALARM

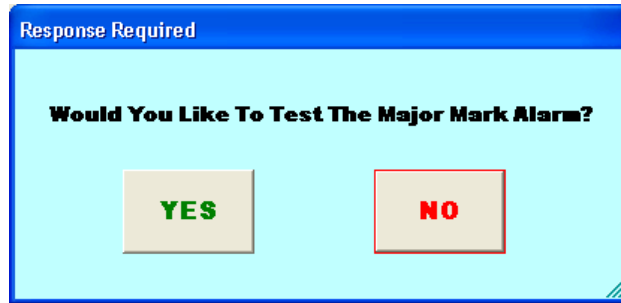

This button will sound the Major Mark alarm. This can be used to verify the alarm is working and to determine if the volume is adequate.

3.2.11.8 MAJOR MARK ALARM OFF



This button silences the Major Mark Alarm until a new alarm condition occurs.

3.2.11.9 MAJOR MARK ALARM VOLUME

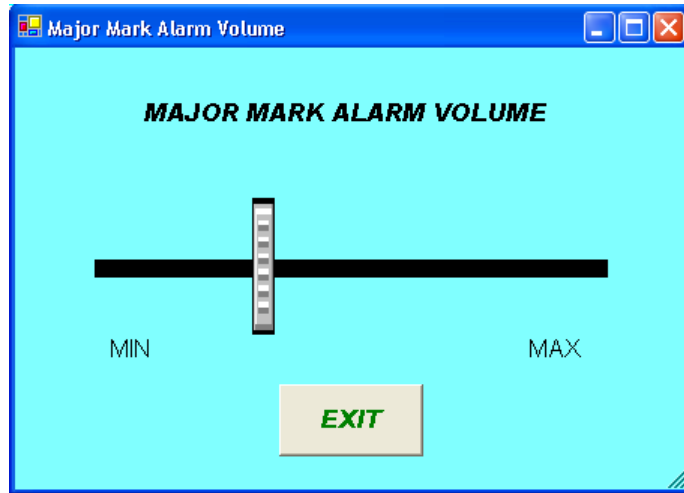

This button will bring up a slider bar which is used to adjust the Major Mark Alarm volume. Use the "Test Alarm" button to test the volume.

Note: Typically, the major mark alarm volume is set higher than the minor mark alarm volume.

3.2.11.10 TEST RELAY

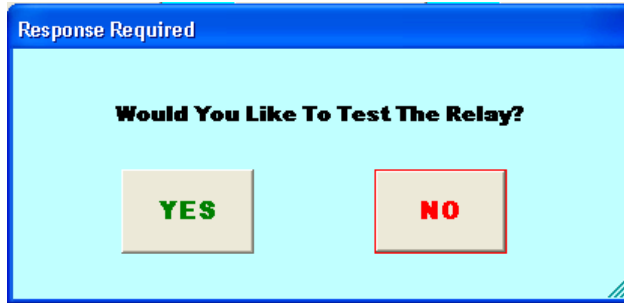

This option is provided to test the relay contact closure. The relay will automatically open in 1 second.

3.2.11.11 OPEN RELAY

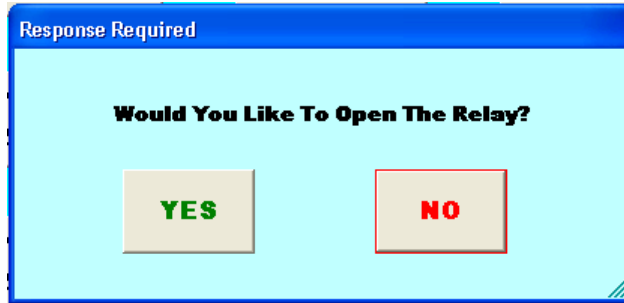

This option is provided for test purposes only in the event that the relay malfunctions and stays 'stuck' closed.

Note: Normally, the relay automatically opens 1 second after closure.

3.2.12 RESTORE DEFAULTS

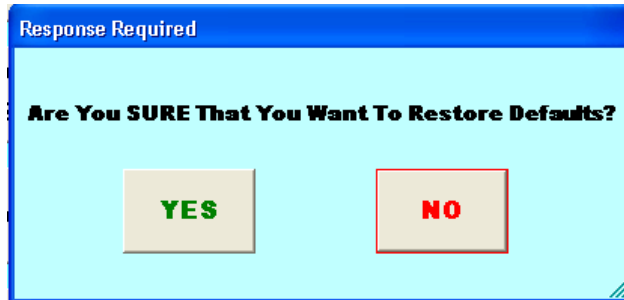

When this button is pressed, all the settings will be restored to their default values. This functions as a software reset. Depth will be zeroed.

3.2.13 RELAY SETTING

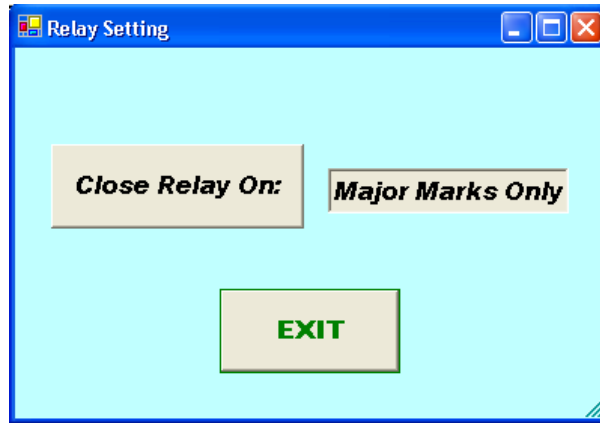

Default: Major Marks Only

This option allows a choice between closing the relay on all marks (minor and major) and major marks only.

The relay contacts can be used to provide a power path to an optional external horn for noisy shop environments.

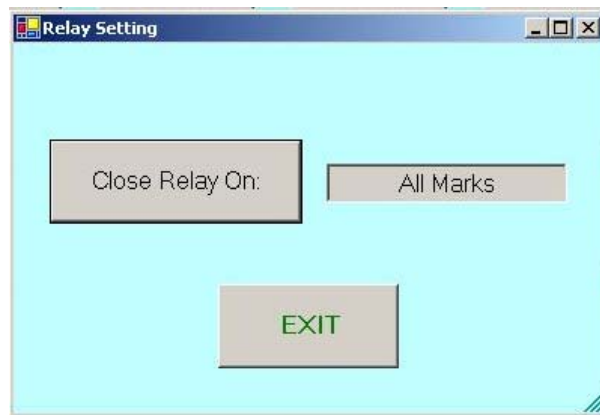

You may also choose to close the relay on all marks, as shown above.

3.2.14 MINOR MARK DIS/ENABLE

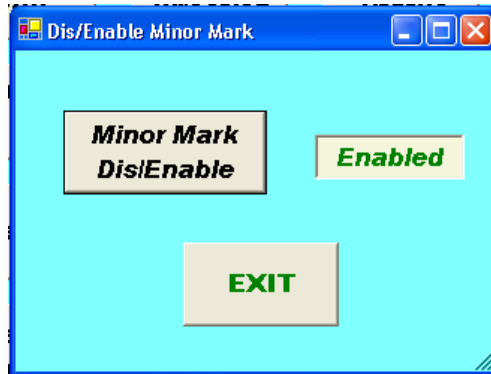

Default: Enabled

Disabling this feature is useful only when spooling marked line with the intention of not placing any additional marks on the line.

Note: In general, leave this option enabled.

3.2.15 SUMMARY

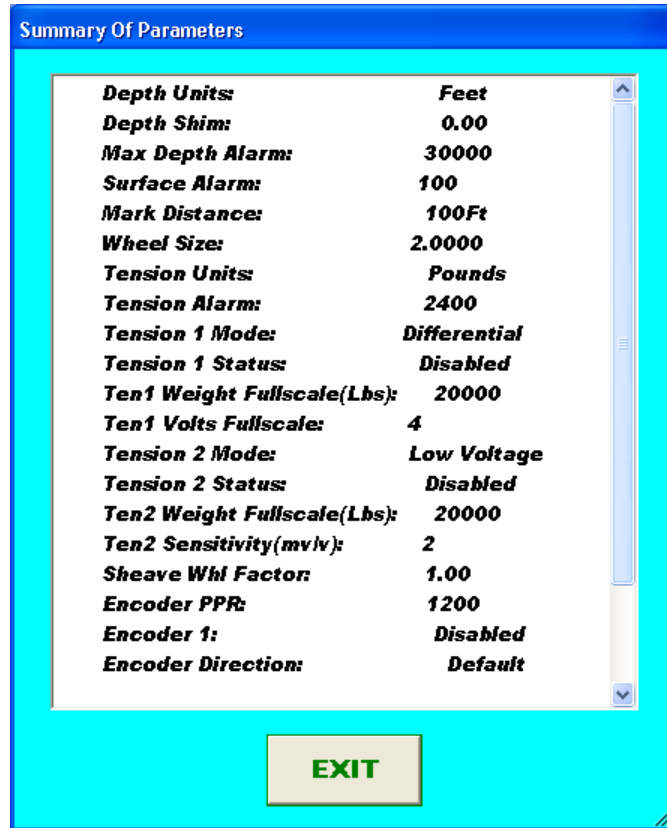

The Summary Menu is a quick reference to what parameters are set. This is a static display.

All of the defaults are shown.

3.3 MARK RESET

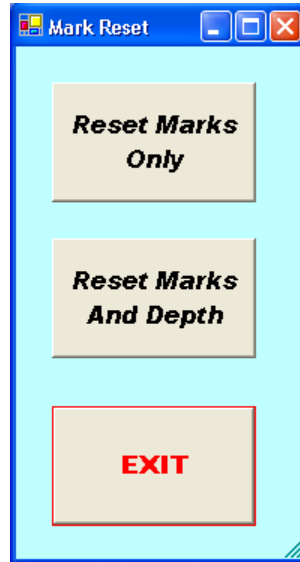

This menu is invoked from the main screen and offers two options for re-setting marks.

3.3.1 RESET MARKS ONLY

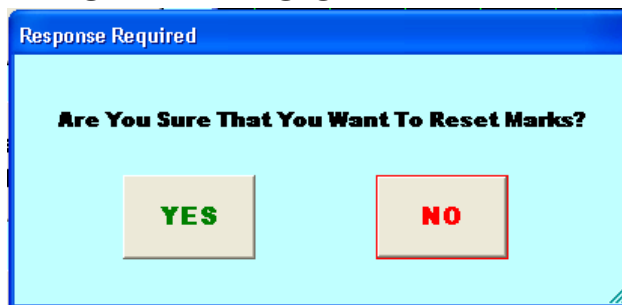

This option resets marks but not depth. Example: The operator has spooled 5,000 feet of line and stopped. He wishes to start marking again and wants the panel to start at 5,000 feet and not at zero.

3.3.2 RESET MARKS AND DEPTH

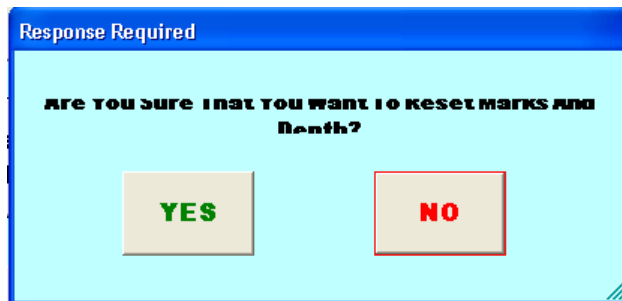

This option resets marks and depth to zero.

3.4 Marking the Cable

The control panel and the measurement arm should be installed as described in section II.

1. Be sure the erase potentiometer is set on "0".
2. Turn on the control panel.
3. Set the threshold (top trace on the CRT) approximately 1 cm. above the lower trace.
4. Increase the erase potentiometer to approximately "50". Adequate degaussing of the cable occurs between 15 and 50 on the erase potentiometer.
5. With the cable not moving and in a position to begin marking, depress the momentary "Manual Mark/Reset" which will apply the first major mark and the first minor mark on the cable.
6. Quickly bring the cable speed up to between 200 and 300 ft. per minute and adjust the reference tension which is usually 1000 pounds while the cable is moving.
7. As the desired cable speed is reached, adjust the threshold as shown previously.

3.5 Variations of Marking

In some cases, it is desirable to locate a previous old mark along the cable and remark from this previous mark.

1. Locate previous good mark with a hand magnetic detector and flag this spot with chalk or paint.
2. With the erase potentiometer at 50, move the cable until this flagged spot is directly under the major marker.
3. Proceed with marking as described above or if preferred this can be done with the cable in motion. Watch for the flagged spot to come beneath the major mark coil and depress the manual mark switch as it passes. Depending on line speed (about 150-200 ft./min. is preferred) and operator technique, this method could result in a 2" – 6" error, but it is a one time non-recurring offset.

3.6 General Comments on Markings

1. The audible tones give a repetitive signal with each mark to aid the operator without continuous visual monitoring.
2. Dramatic reduction of cable speed (i.e. from 400 ft. per minute to 100 ft. per minute) will require a reduction in the threshold setting. Quick increases in cable speed will require an increase in the setting in the threshold to ensure that it is above noise level to count only on interval marks and not on general noise level.
3. If for any reason restarting the marking job is required, the cable must be backed up with the erase current at 50 to eliminate and interval (minor marks) or other magnetic noise on the cable. Locate the last good major mark with a hand detector and place it underneath the major marker coil and then start the marking sequence as described above.

3.7 Metric System

The Metric System includes an English/Metric function switch on the rear panel and a metric measurement base (top arm).

1. Remove the 10 contact connector between the measurement base and the frame.
2. Remove the shoulder bolt holding the measurement base.
3. Replace the English measurement base with the Metric measurement base reversing steps one (1) and two (2).
4. Place unit in "Metric" mode and operate as previously described (refer to paragraph 3.2.6).
5. The Metric measurement base is 1 2/3 meters rather than 5 feet in length.

Section 4 – Troubleshooting

Marking problems are of two types: either the unit does not apply marks to the cable and it is evidenced by no audible or visual indication of the interval marks or the problem would be multiple marks where the counter is detecting noise in addition to the interval marking resulting in major magnetic marks at 50 ft. or 33 1/3 ft. etc. This is easily recognized by the change in rhythm of the audible interval mark tones.

4.1 No Marks

1. Threshold set too high.
2. Line speed too low.
3. Measurement base arm not riding properly on cable.
4. Oversize cable.
5. Loose connectors on measurement arm.
6. Umbilical damage causing open conductors.
7. Open in the detector or interval mark circuit which would be recognized by the meters not discharging voltage with each mark.

4.2 Multiple Marks

1. Threshold set too low – ambient noise from the cable penetrating the threshold and activating the counter.
2. Eraser (degaussing coil) hitting the cable.
3. Bouncing and erratic movement of the cable causing the measurement arm to bounce upon the cable.
4. Improper ground of the system creating noise (rf noise coming through the cable as an antenna and being picked up by the detector).
5. Excessively ropy cable causing the detector to rise above the cable.
6. Open conductor in the erase circuit (erase light will not be on).

7. Too low of a setting on the erase potentiometer.
8. Umbilical damage causing open in the erase circuit or short in the detector circuit.
9. Spurious signals on the cable that penetrate the threshold line (i.e. truck air conditioner, computer, other support equipment) operating through an improperly grounded power system
10. Moisture in umbilical connectors, detector or erase transformer box.
11. Minor marker or detector “gummed” or stuck with corrosion and not free to rotate easily on brass mounting bolts.

Section 5 – Features and Specifications

5.1 NEW PANEL FEATURES

- 120 - 240 VAC 50-60 HZ Power Input

- Improved minor mark detector
 1. Digital scope card provides more reliable display of minor marks
 2. Improved low noise minor mark detector circuitry
 3. New design allows marks to be installed accurately over a wider range of speeds
 4. Double mark warning and alarm are activated when a double mark condition is detected.

- Data recorder and printout
 1. Mark, depth, and tension data stored to internal memory card
 2. Data can be printed to a printer through a USB port
 3. Data can be moved to a USB thumb drive for plotting with an external PC

- Intercom
 1. Remote speaker connects to the intercom output
 2. Remote speaker serves both as a speaker and microphone
 3. Optional remote speaker with cable spool of upto 250' in length

- Internal PC board
 1. Intel based personal computer board
 2. 1 GB solidstate media device
 3. Embedded windows XP operating system
 4. Two USB ports
 5. USB Mouse / Keyboard included

- Color Display
 1. TFT LCD
 2. Backlit
 3. 400 NITS Sunlight readable
 4. Touch Screen Interface (replaces current key pad)
 5. 5 wire resistive
 6. USB interface

- Real Time Acquisition board
 1. Proprietary design based on 8051 Microprocessor
 2. Provides power to encoders, magnetic mark detector, and load cell
 3. Processes encoder quadrature pulses, magnetic mark signal, and load cell
 4. Runs independent of windows embedded PC

5.2 SIZE AND WEIGHTS

Frame: 103" L. x 12" W. x 23" H. – 95 pounds
2616 mm L. x 305 mm W. x 584 mm H. – 43 Kg.

Umbilical Cable: 30 ft. long – 12 pounds
9.1 M. long – 5.4 Kg.

Panel Case

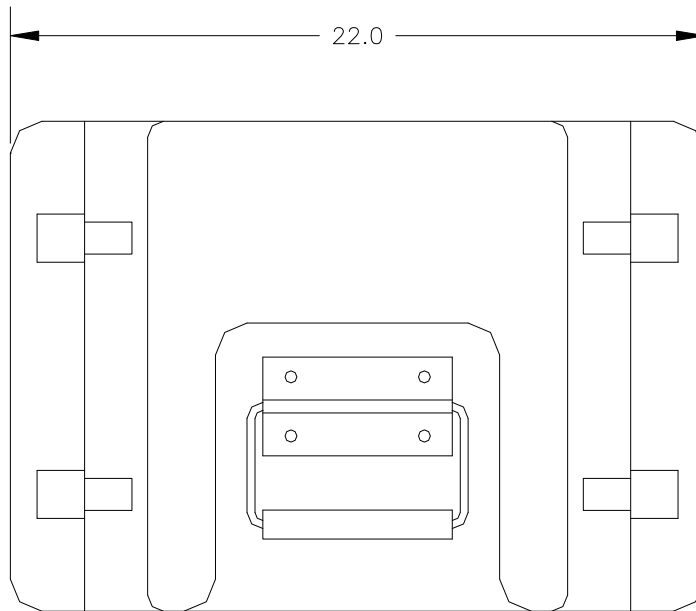

OUTER CASE SIDE VIEW

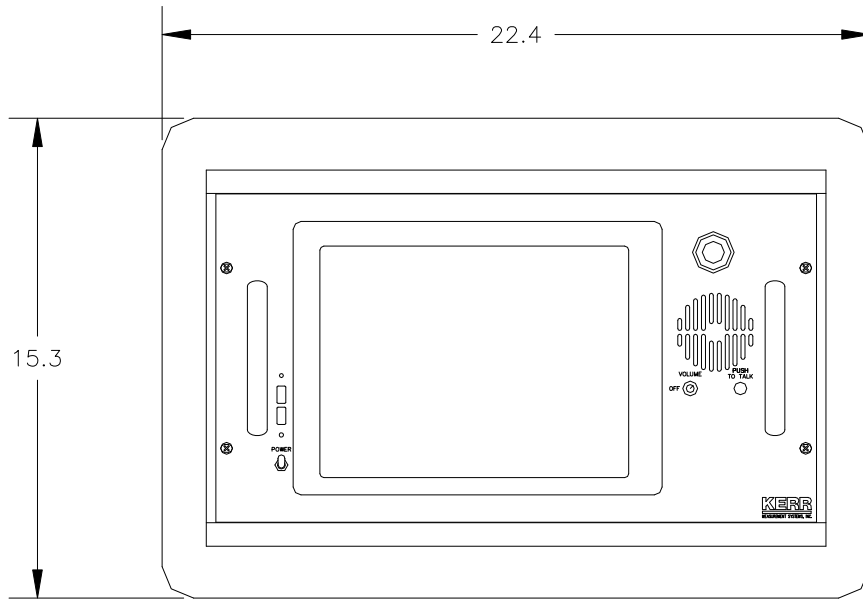

FRONT VIEW

CRATES (weights with equipment inside):

Base and Frame Crate: 106" x 26" x 12" - 150 Lbs
 2692 mm x 660 mm x 305 mm – 68 kg

5.4 Procedure for Checking ACMU Minor Marker / Detector Polarity

1. Install minor marker and/or detector on measurement base.
2. Install marking unit on cable to mark using standard marking procedures.
3. Set threshold on ACMU control panel very low during this procedure.
4. Mark cable at 250 to 300 ft/min and monitor the minor mark signal on the oscilloscope in the ACMU control panel.
5. If the minor mark/detector polarity is reversed it will look like the figure "B".
6. To correct reversed polarity remove the minor marker bulkhead receptacle from the top arm. Remove the two wires from the back side of the connector. Reverse the two wires and reconnect.

5.5 ACMU Reverse Magnetic Mark Polarity

One preference is for the polarity of the magnetic marks on the logging cable to be uniform from cable to cable and to be oriented with the positive pole toward the logging truck.

Check the marking system first by applying a few marks to a cable and test with a hand held gauss meter. The meter should deflect to the positive side of the scale on the truck side of the magnetic mark then through zero and then negative.

If you need to reverse the polarity of the magnetic mark do so at the top arm connector of the major mark coil.

Remove the 4 6-32 socket head cap screws, holding the major marker bulkhead connector to the top arm. Pull the connector away from the top arm about 3-6 inches. The connector has two wires soldered to it on the back side (one orange & one green). Unsolder these wires, reverse them and re-solder to the connector pins.

Re-attach connector to the top arm and check magnetic mark polarity.

FIGURE 7 – ACMU MARK POLARITY

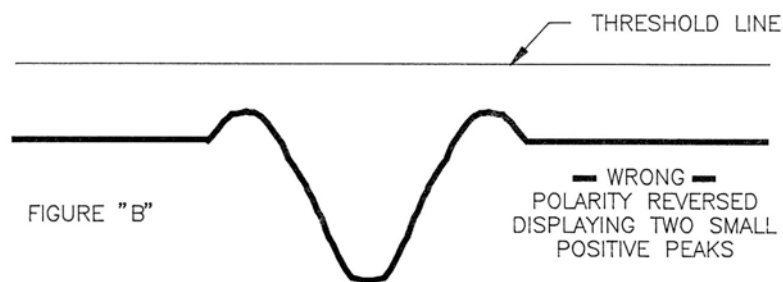
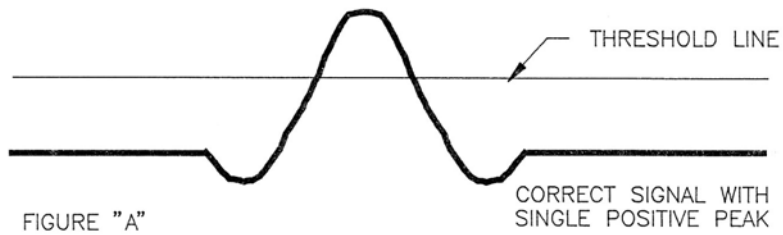

5.6 RECOMMENDED SPARE PARTS FOR ACMU

QTY	P/N	DESCRIPTION
1	ACMU3M31	Measurement Base Complete with Marker, Detector And Major Marker
1	ACMU3A09	Coil Major Mark Assembly - English
1	ACMU3A10	Coil Major Mark Assembly - Metric
1	ACMU3A06	Coil Detector Assembly – English
1	ACMU3A07	Coil Detector Assembly – Metric
1	ACMU3A08	Coil Minor Mark Assembly (English and Metric)
1	ACMU2M18	Wheel 6" R&K 6 X 1.5 5/8-MR
1	ACMU2P02	Wheel 4" MR-04101-10 5/8
1	ACMU2P26	Coil Erase #6 AWG Solid copper wire
1	ACMU2A16	Erase Transformer Assembly (ACMU2P04 & ACMU2P11)
1	ACMU2A18	Erase Coil Insulator & Mounting Hardware Kit (w/ wing nuts)
1	ACMU2P21	Umbilical Cable Connector
1	ACMU1A11-30	30' Umbilical Cable
1	ACMU1A11-05	5' Umbilical Cable
2	ACMU3M11	Brass Swivel Pin
2	ACMU3M12	Brass Swivel Pin
1	ACMU2P03	Eraser Transformer Box (729M)
1	AMS6A001	Hand Held Gauss Meter
1	ACMU1P75	Transformer - 115 And 220 In, 115 out
1	ACMU1P86	Receptacle, 115 – 240 VAC in with selector, fuse, RFI filter

5.7 PANEL LAYOUT DRAWINGS

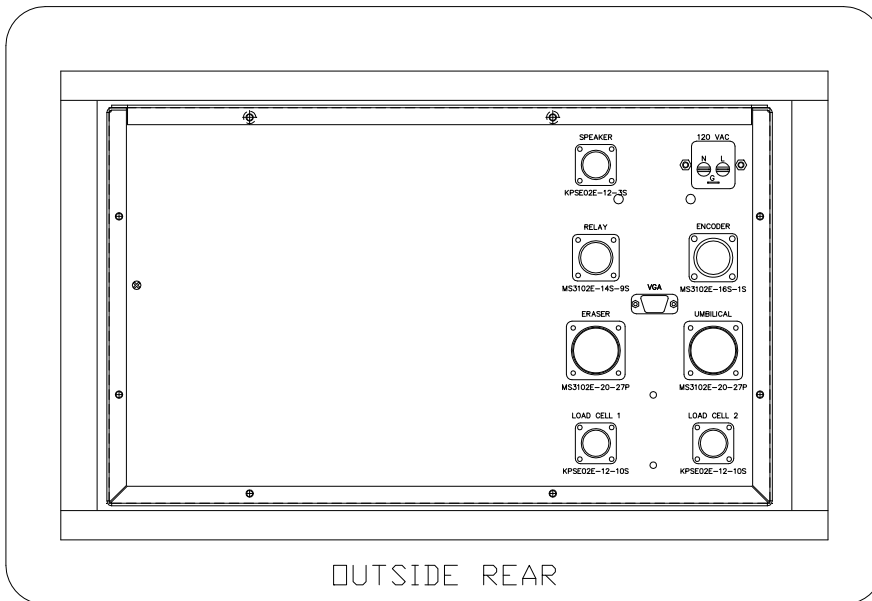
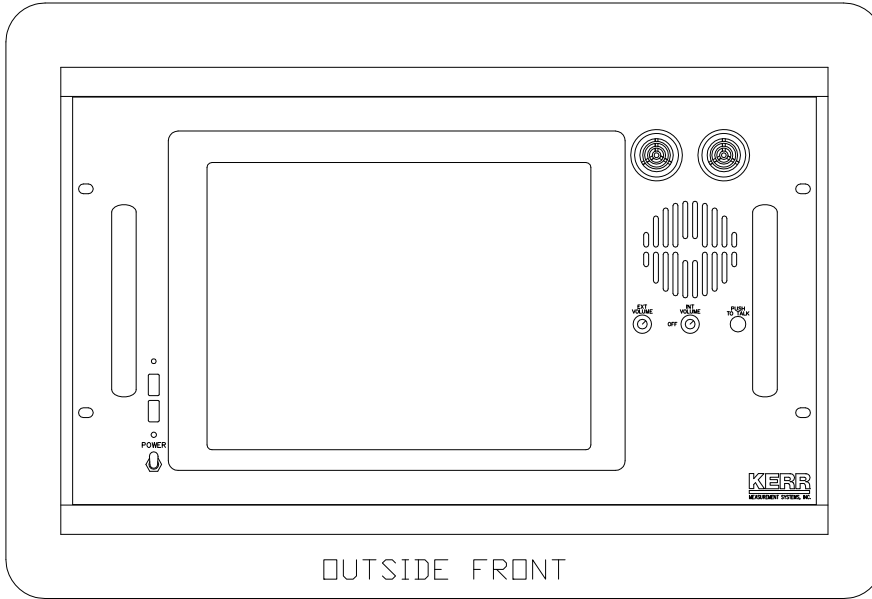

6.0 ELECTRICAL DIAGRAMS AND SCHEMATICS

6.1 BLOCK DIAGRAM

6.2 REAR PANEL CONNECTOR PINOUTS

6.3 WIRING DIAGRAM

6.4 CABLE DRAWINGS

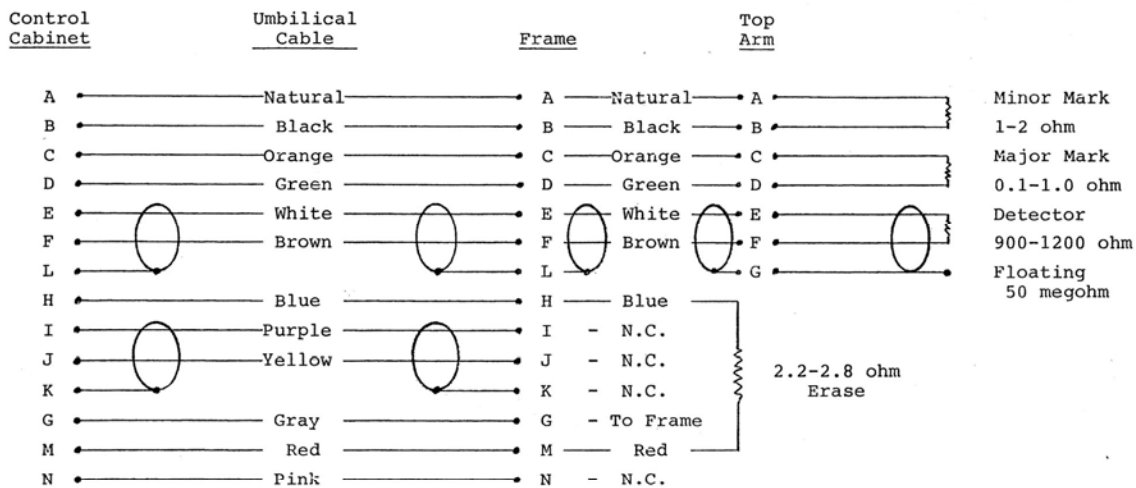

Note: All contacts except "G" must be greater than 50 megohm to each other and to frame except as noted.

6.5 INTERNAL PROCESSOR BOARD PINOUT

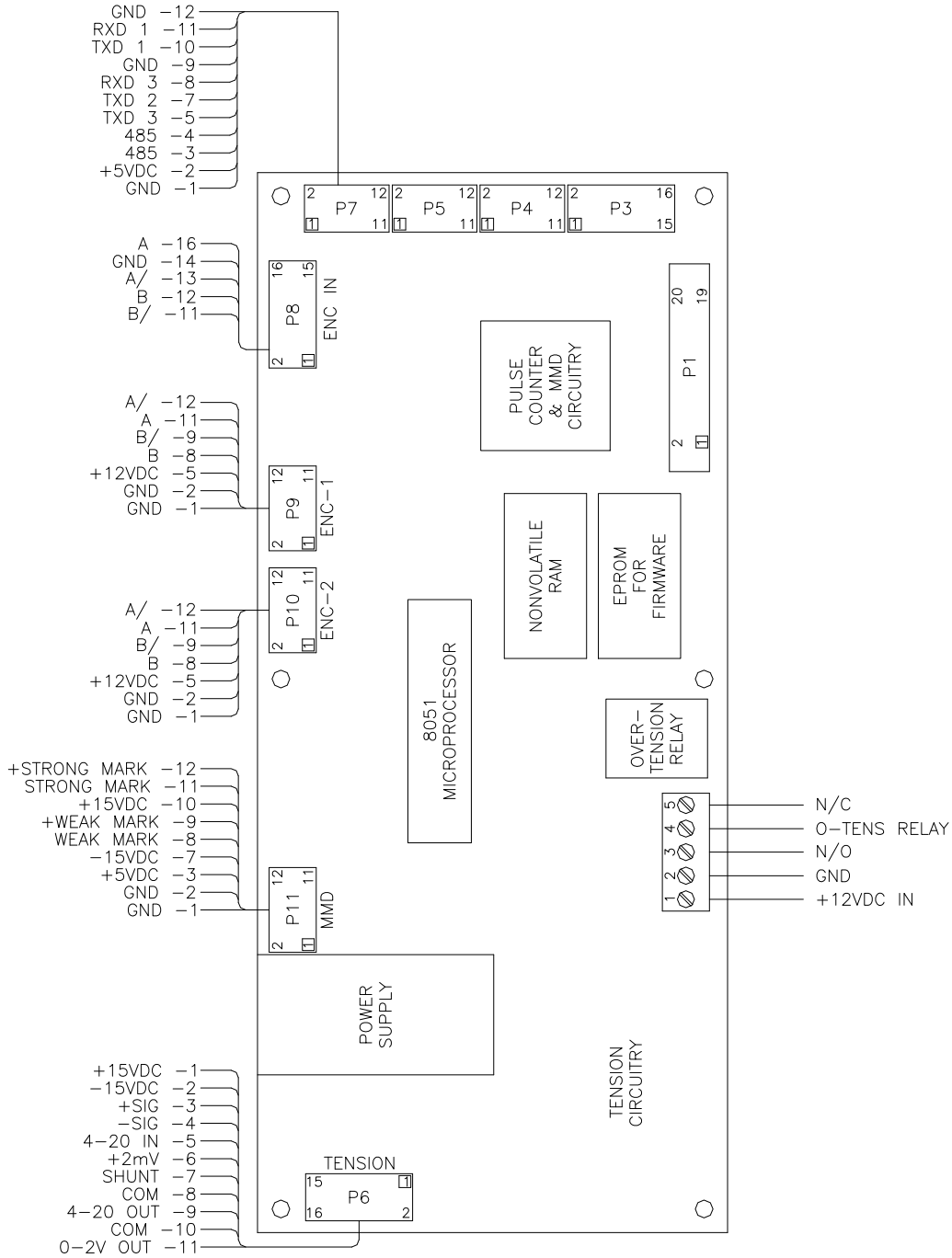

6.7 ENCODER OUTPUT AND COM PORT I/O

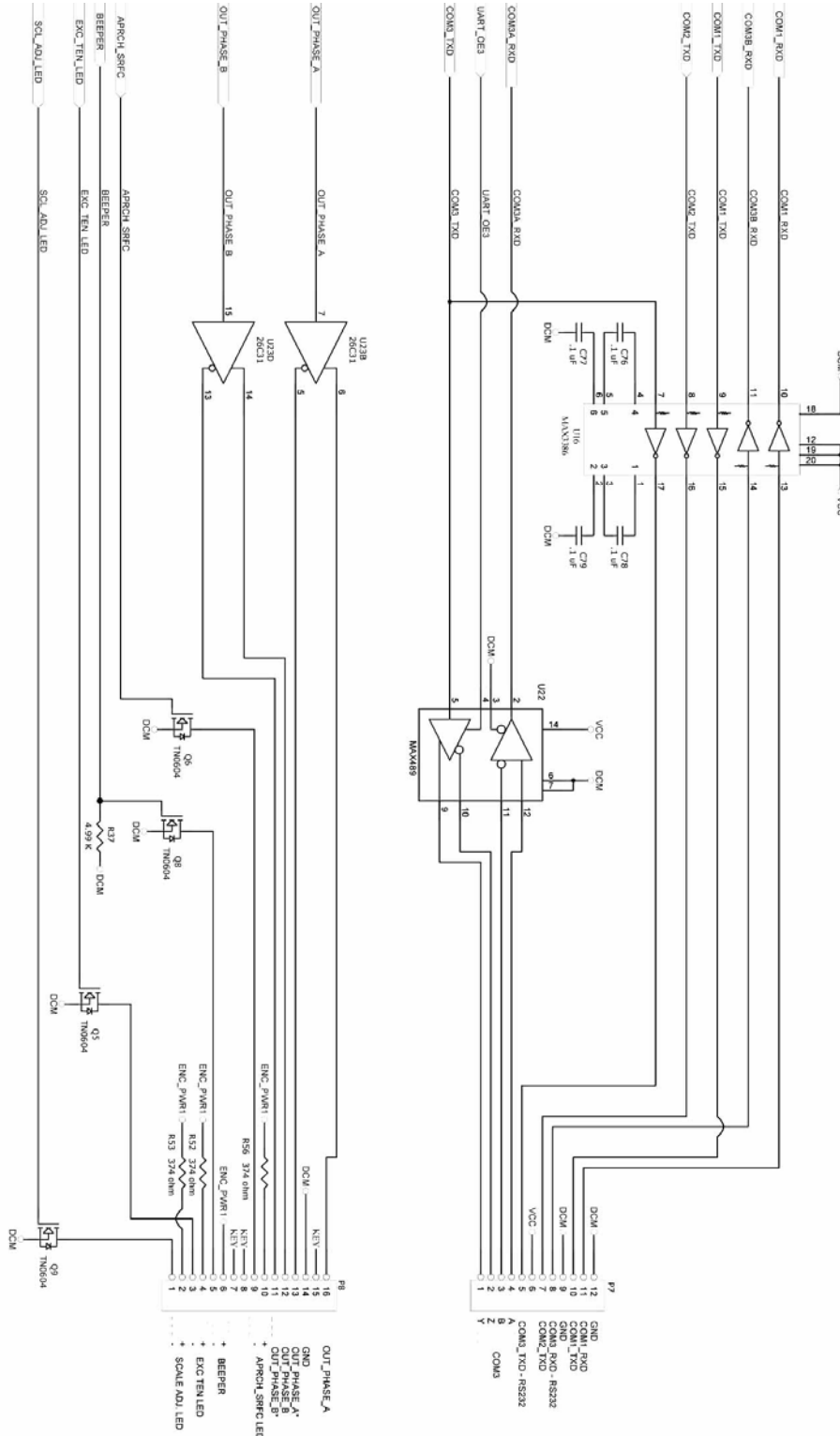

6.8 LOAD PIN AND TENSION I/O

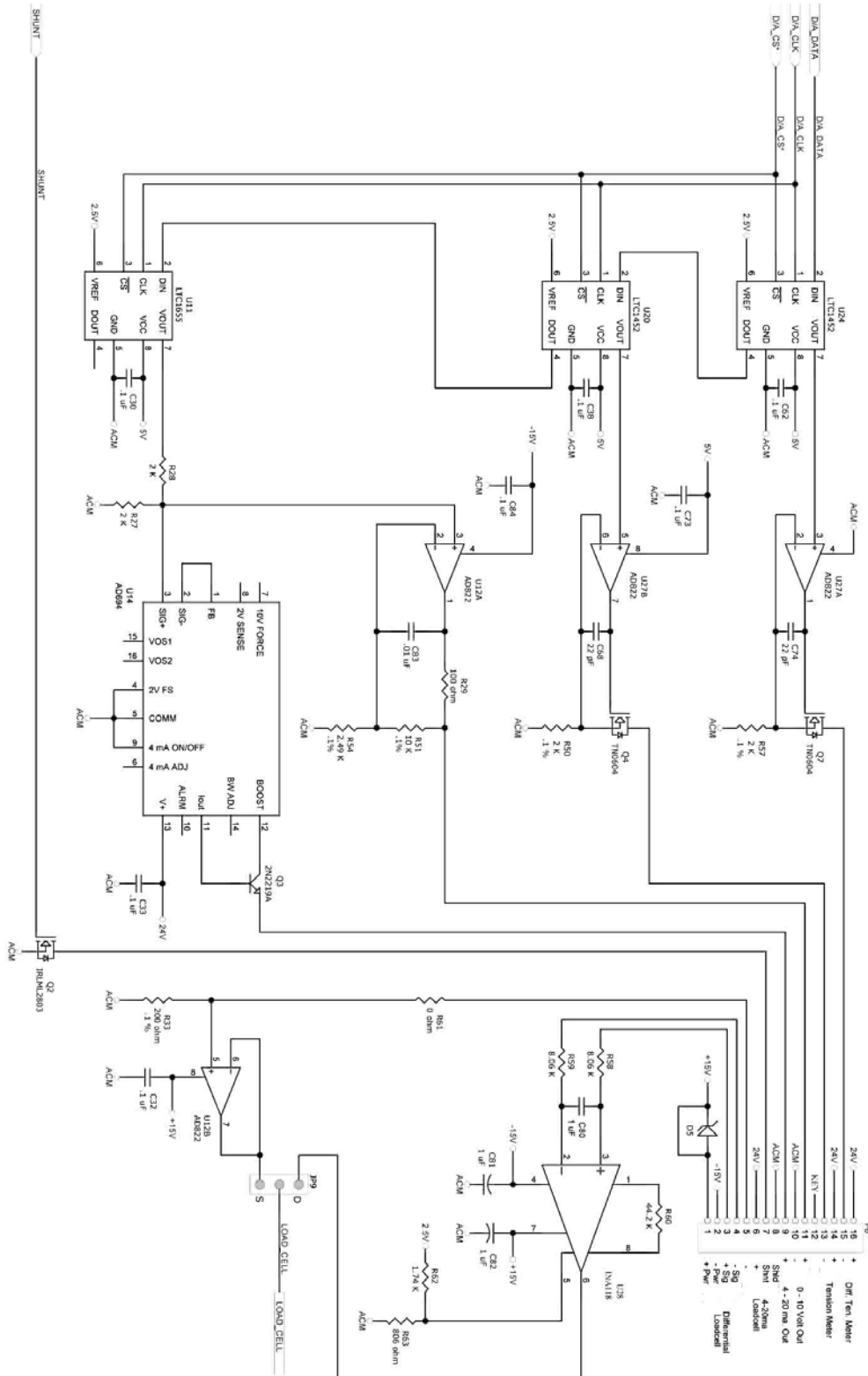

6.9 JUMPERS – BUTTONS

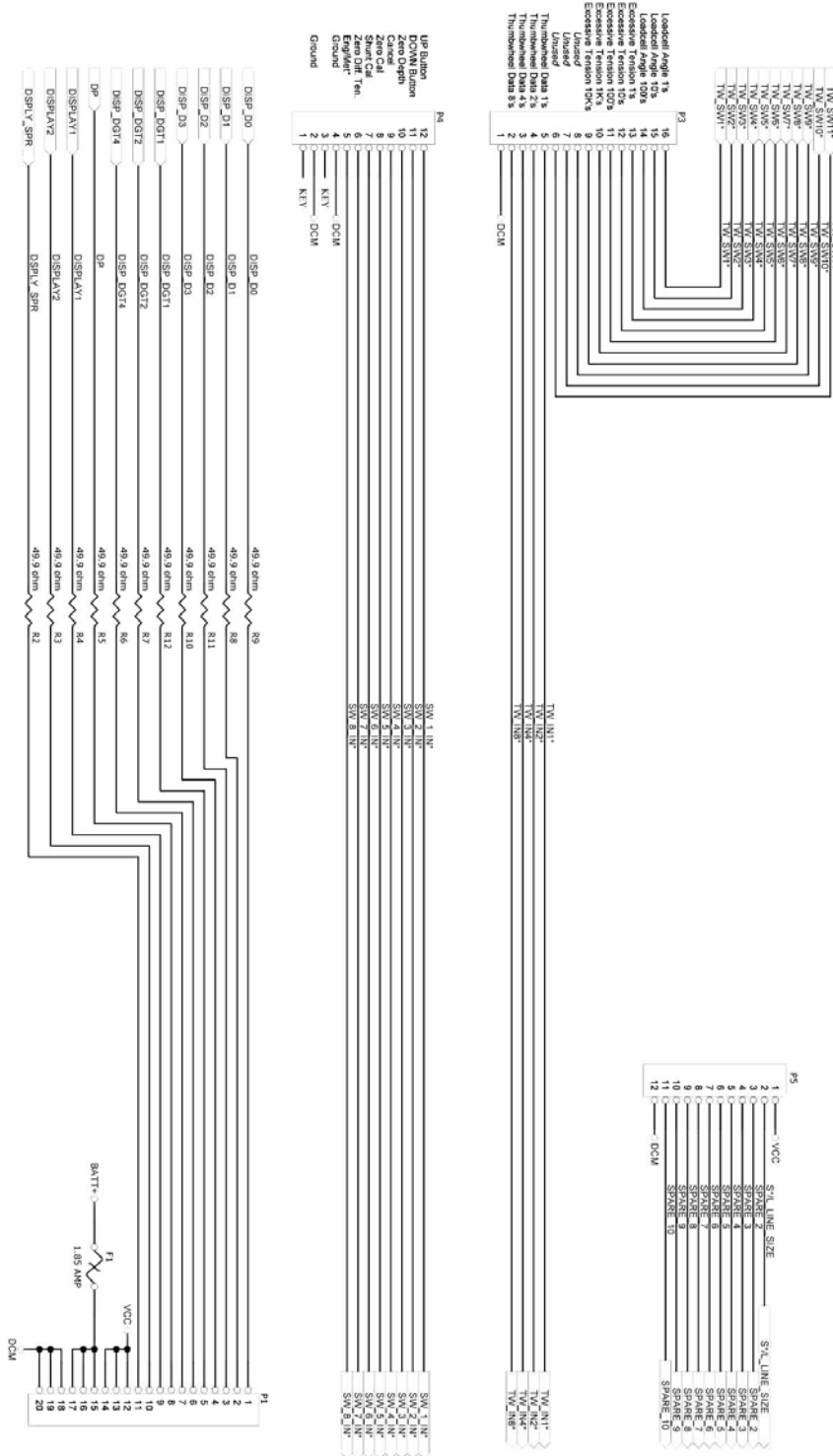

6.10 POWER SUPPLIES

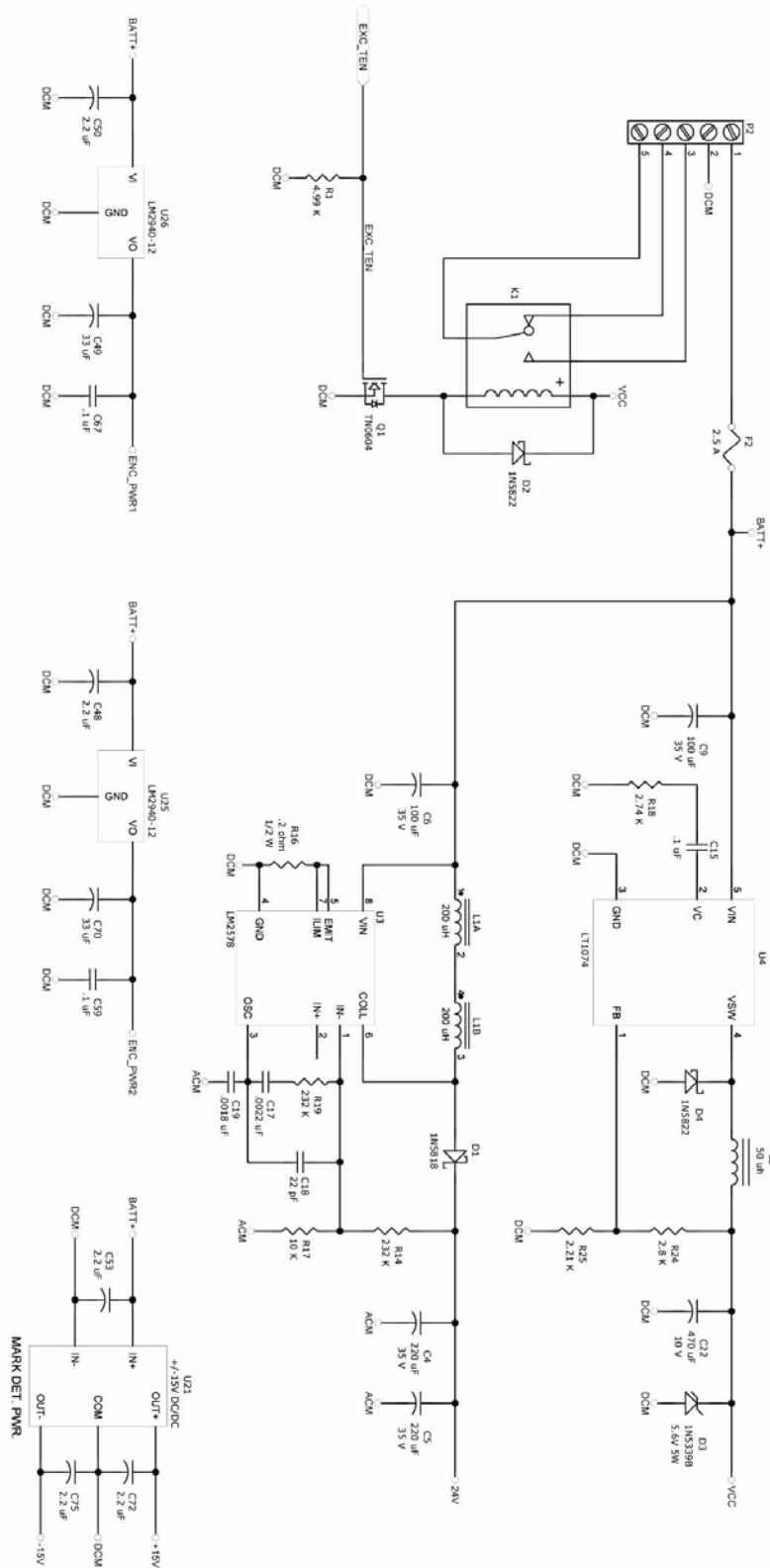

6.11 PARTS LIST – PANEL

ACMU6A01

PANEL ASSY ACMU TOUCH SCREEN

Part Number	Description	Qty
AMS4P134E	PC BOARD AMS40 REV E W/2xRS232	1
AMS4P326	COMPUTER SINGLE BOARD 650MHZ	1
AMS4P319	LICENSE WINDOWS XP EMBEDDED	1
AMS4P318	MEMORY RAM 256MB PC133 SODIMM	1
AMS5P041	MEMORY COMPACT FLASH 4.0GB	1
AMS4P691	FUSE 2.5A 250V 5MM X 20MM GMC	2
AMS4A204	PCB ASSY IN CIRCUIT PROGRAMMG	1
AMS4P577	LCD 12.1 COLOR TFT SHARP	1
AMS4P513	SCREEN TOUCH RESISTIVE 12.1 4W	1
AMS4P511	CNTROLLER BD TOUCH PNL USB	1
AMS4P874	INVERTER CCFL 12VIN 1200V 5.5M	1
ACMU6P40	OSCILLOSCOPE PC 2 CHAN	1
AMS4P779	POWER SUPPLY LPT44 115VAC IN	1
AMS4A322	PCB ASSY VOLUME BRD	2
ALS3A034	PCB ASSY NTERCM 3" MONO W RLYS	1
AMS4A566	CABLE ASSY LANNER VID HIRSE41	1
AMS4P307	SONALERT SC616N MALLORY 4-16V	2
ALS1P032	SPEAKER ALNICO 8 OHM 2W 77MM	1
AMS4M136	BEZEL LCD 12.1" LCD SHARP TUCH	1
ACMU1M35	CHASSIS 10-1/2 TOUCH SCR N ACMU	1
ACMU6M33	PANEL REAR TOUCH SCREEN ACMU	1
ACMU6M32	PANEL FRONT TOUCH SCREEN ACMU	1
AMS4M034	PANEL TOP TOUCH SCR N OH OP PNL	1
ALS1P011	POT 250 OHM CLAROSTAT 381N250	1
AMS4P362	POT 500 OHM 1/4W CARB LNR W/SW	1
AMS4P363	KNOB INSTRUM SKIRTED RND .5"DI	2
AMS4P021	SWITCH CAP ALCO C-22 BLACK	1
AMS4P018	SWITCH SPDT PUSH MOM MPA-106F	1
AMS4P028	SWITCH DPDT TOGGLE LOCKING	1
AMS4P290	TERMINAL INSULATED SOLDR 6-32	2
AMS4P739	CABLE SVGA EXTENSION SUPR THIN	1
C276P155	CABLE BELDEN 177431 10' AC	1
AMS4P512	CABLE RTP/USB 4 WIRE FUJITSU	1

AMS4P304	CABLE USB X 2 PANEL MOUNT	1
AMS4P877	CABLE INVERTER CCFL INPUT TO	1
AMS4P878	CABLE INVERTER CCFL OUTPUT TO	1
AMS7P021	CONN 102398-4 AMP 12 POS PCB	6
AMS4P179	CONN KPSE02E12-3S RECEPTACLE	1
ACMU3P01	CONN MS3102E-14S-9P RECEPT	1
AMS4P038	CONN MS3102E-16S-1S 7 SOC RCP	1
AMS4P276	RECEPTACLE 115/240 VAC FUSED	1
AMS4P168	SOCKET AMP M39029/63-368 USED	3
AMS4P167	PIN AMP M39029/64-369 USED	3
AMS4P581	CONN HOUSING 4POS .2 DISK PWR	1
AMS4P582	TERM CONN FEMALE CRIMP DISK PW	4
AMS1P052	SCREW 10-24 X 5/8 SOC HD SST	2
AMS1P054	WASHER #10 FLAT SS	2
C276P035	WASHER #10 LOCK SS	2
F244888000	HANDLE OVAL 1-1/2 X 4-9/16 AL	2
ALS3P018	STANDOFF 8-32 X 1 M/F HEX	4
AMS8P092	SCREW 6-32 X 3/8 FH PHIL SST	34
AMS4P583	CONN HSG 10 POS 2MM MILLI-GRID	2
AMS4P584	TERM CONN FEM CRIMP 2MM 24-30	10
ACMU1P70	CONN 09-50-3031 MOLEX W/LOCKNG	1
ACMU1P71	CONN 09-50-3061 MOLEX W/LOCKNG	1
AMS4P596	CONN 09-50-3101 MOLEX W/LOCKNG	1
AMS4P675	TAPE DBL SIDE 1/32 X 1 MMM	24
AMS4P590	KEYBOARD USB MINI TOUCH BLACK	1
AMS4P330	CONN .1 CRIMP TERM HOUSING 4CT	2
AMS4P331	CONN CRIMP PIN FOR AMS4P330	8
AMS4A740	PCB ASSY FUSE BD TCHSCREEN BAT	1
AMS4P738	DUSTCAP PLUG CAPUSB-A	2
ACMU6A20B	PCB ASSY MINR MRKR ACMU2 REV B	1
ACMU6A21	PCB ASSY MAJOR MRKR ACMU2	1
AMS4P867	CONN BNC MALE BLACK AND RED	2
ACMU1A50	PCB ASSY TENSION #2 ACMU	1
AMS4A213	PCB ASSY ENCDR PULL UP FUSE #2	1
ACMU6P01	CASE MOLDED 6U PRORACK HARDIGG	1

6.12 PARTS LIST – ERASE TRANSFORMER

ACMU6A02

PANEL ASSY ERASE TRANSFORMER

Part Number	Description	Qty
ACMU1P15	POWERSTAT (TYPE 10C)	1
ACMU1P75	TRANSFORMER 115 AND 220 IN 115	1
ACMU6P02	CASE CARRYING HARDIGG	1
ACMU1P86	RECEPTACLE 115,240 VAC IN WITH	1
ACMU1P21	CONN MS3102E-20-27P 14 PIN	1
FSU1P031	NUTPLATE SHELL 20 4-40	1
C276P155	CABLE BELDEN 177431 10' AC	1
ACMU6M13	ACMU MAGNETEK N66A MOUNT	2
ACMU6M22	PANEL FRONT ERASER ACMU	1
C276P627	SCREW 1/4-20 X 1 BTN HD SST	8
C276P036	WASHER 1/4 LOCK SS	8
ACMU2P31	WASHER 1/4 FLAT 5/8OD SST	8
ACMU1P28	LAMP #CM967 110 VOLT	1
ACMU1P59	LENS CAP RED DIALIGHT #052-319	2
ACMU1P13	LAMP HOLDER DIALIGHT	2
AMS5P021	FUSE 3.15A 250V 5MM X 20MM	2
AM5KP041	SCREW 10-24 X 1-1/4 PHIL PAN	4
C276P035	WASHER #10 LOCK SS	4
AMS1P054	WASHER #10 FLAT SS	4
C276P149	NUT 10-24 MACHINE SS	4
ACMU1P36	RESISTORS #RH25 DALE 25 WATTS	1
ACMU1P20	SWITCH 7803K33 EATON ON/OFF	1
ACMU1P29	LAMP #CM-47 6 VOLT	1

7.0 SOFTWARE UPDATE PROCEDURE

PREREQUISITES:

1. USB keyboard/touchpad.
2. USB floppy drive or USB CompactFlash card reader or USB thumb-drive or equivalent or a Ethernet connection with the new revision real-time data acquisition HEX file program.

PROGRAM UPDATE (PC BASED PROGRAM)

1. Close all running programs in Windows XP Embedded.
2. Copy ACMU.EXE to the directory C:\ Program Files\Kerr\
3. Shutdown Windows XP Embedded, and cycle power. When the Hoistman Display program comes up check the HELP – ABOUT menu and confirm that both software versions are at the latest revision.

REAL TIME BOARD PROGRAM UPDATE (AMS40 BOARD)

The following Instructions for programming the DS89C450 MicroController's internal Flash memory with the real-time data acquisition program.

NOTE: the rear panel screws need to be removed to gain access to the switches on the CPU piggy-back PCB.

1. Close all running programs in Windows XP Embedded.
2. Copy the file ACMU.HEX file to the root directory C:\

Transfer these files to the CompactFlash (C:\) root directory via Ethernet or USB connection using the Windows Explorer

3. Open a Hyperterminal session. Use the following settings:

Serial Port: COM1
Baud Rate: 57600
Data Bits: 8
Parity: None
Stop Bits: 1

SW3 - position towards CPU

Wait approximately 10 seconds

11. After the ROM Loader is finished programming the Flash and the MEMDISK program is complete set the switches on the piggy-back PCB as follows:

SW1 - position towards CPU

SW2 - position towards CPU

SW3 - position away from CPU

12. HyperTerm uses the same serial port as the Hoistman program, so close it before opening the Hoistman program.

8.0 PRINCIPALS OF MAGNETIC MARKING OF LOGGING CABLE

Confirming Magnetic Mark Intervals on Logging Cables

8.1 Background

Magnetic marks are placed on logging cable at a known interval and at a known tension to aid in depth measurement while logging. Typical intervals are 100ft., 25 meters or 50 meters. The tension on the cable at the time of marking is usually 1000 pounds (453.6kg).

These magnetic marks are counted as the logging cable is run down-hole and a measuring wheel is used to interpolate between marks. Various procedures are used to correct and adjust the measuring wheel depth indicator to agree with depth as counted by the magnetic marks. With the logging tool down-hole, usually at T. D., the cable is stopped and direction reversed for a few feet at logging speed to determine maximum line tension.

The depth as measured by counting magnetic marks is adjusted for cable stretch by using an elastic stretch equation or a "stretch chart" format.

The simplified equation for determining cable elastic stretch is:

$$\text{Amount of elastic stretch} = \frac{KLm \times (T-2Tm)}{2}$$

K= elastic stretch coefficient
(ft./1000 ft./1000 lbs.)

Lm= depth as measured by magnetic marks
(in 1000's of feet)

T= maximum line tension
(in 1000's of pounds)

Tm= marking tension
(in 1000's of pounds)

The amount of calculated stretch is then added to the depth as measured by counting the magnetic marks to give actual depth or "elastic stretch corrected depth".

Another factor affecting measurement of true depth is in-elastic stretch or

permanent stretch of logging cable. All logging cables stretch permanently the first few trips in the hole. This is due to the tension and the fact that the tool is free to rotate. The cable unwinds and becomes permanently longer.

Permanent stretch is difficult to predict accurately but the amount is significant; up to 0.5% or 50 ft. in 10,000 ft. before a cable is “stabilized” to a given depth and tension. Also if the “stabilized depth” or “stabilized tension” are exceeded then there will be more permanent stretch.

New cables should be re-measured and magnetically marked after the 1st, 3rd, 5th, 10th, and 20th job. Stretch records should be kept to determine at what depth and tension a cable is “stabilized”.

8.2 Magnetic Marking and Depth Measurement

Excluding permanent stretch there are four variables that affect depth measurement when using the magnetic mark principle of measurement.

- magnetic mark interval
- marking tension
- elastic stretch coefficient
- maximum logging line tension

This procedure is directed at confirming the magnetic mark interval however, the other three factors should be checked and confirmed on a routine basis.

8.2.1 Marking Tension

Marking tension has generally standardized throughout the world at 1000 pounds (453.6 Kg.) over the past 20 years.

8.2.1.1 Measure marking tension with a load measuring device that provides at least a 50 pound resolution.

8.2.1.2 The load measuring device should be sized for the measurement to be made. A 0-2,000 pound device would be ideal. Attempting to measure 1000 pounds with a 40,000 pound load cell will always provide very questionable accuracy and resolution.

8.2.1.3 Have the load measuring device calibrated routinely according to the manufacture’s recommendation.

8.2.1.4 Hydraulic load measuring system vary with temperature, particularly at low loads (1000 pounds). Measure and record the surface temperature of the hydraulic piston during marking. Correct for temperature according to the manufacturer's instructions. Errors of up to 1000 pounds are possible in a single day; from a cool morning to a hot afternoon in direct sunlight.

8.2.1.5 Always install the logging units load cell in the marking set-up to check the logging load cell against the calibrated marking load cell.

8.2.1.6 Example – Assume 10,000 ft. hole, 4,000 pounds maximum line tension and a 7/16" multiconductor cable with an elastic stretch coefficient of 0.8.

A typical stretch chart assumes marking of 1,000 pounds and would show stretch as:

$$\text{Stretch} = \frac{0.8 (10) \times [4 - 2 (1)]}{2}$$

$$= 4 \times 2 = 8 \text{ feet}$$

If marking tension was wrong due to poor marking tension measurement and the actual marking tension was 1,500 pounds then the correct stretch should have been:

$$\text{Stretch} = \frac{0.8 (10) \times [4 - 2 (1.5)]}{2}$$

$$= 4 \times 1 = 4 \text{ feet, a 4 foot depth error.}$$

8.2.2 Elastic Stretch Coefficient

The elastic stretch coefficient of logging cable varies with each size, armor package design and number of electrical conductors.

8.2.2.1 Verify the elastic stretch coefficient with the cable manufacturer or measure it directly for your cable in the tension range expected during logging.

8.2.2.2 Example – using the numbers in the example described in 8.2.1.6 the cable stretch was 8 ft.

If the actual stretch coefficient was 1.3 ft./1000ft./1000 pounds then:

$$\text{Stretch} = \frac{1.3 (10) [4 - 2 (1)]}{2}$$

= 6.5 x 2 = 13 ft. a 5 foot depth error.

8.2.3 Maximum Line Tension

Maximum line tension should be measured with the tool moving up at the anticipated logging speed. This operation should be repeated 2-3 times to ensure correct maximum tension.

8.2.3.1 Have the logging unit load cell calibrated on a standard routine according to the manufacturer's instructions. Keep calibration records and insure that calibration is done through the normal logging tension range.

8.2.3.2 Example – Using 2.1.6 again but assuming maximum tension was in error by 500 pounds.

$$\text{Stretch} = 0.8 (10) [4.5 - 2 (1)]$$

= 4 x 2.5 = 10 ft. a 2 foot depth error.

8.3 Magnetic Mark Interval

Confirming magnetic mark interval is sometimes difficult to do correctly but should be done after every marking job.

Assuming 100 ft. mark intervals an error of 1 inch creates an accumulative built in error of 8.3 ft. in 10,000.

A good marking operation should result in magnetic marks 100 ft. plus or minus 0.1 inch.

8.3.1 Equipment

8.3.1.1 Calibrated tape measure Lufkin type C1676D or equivalent with temperature correction scale.

8.3.1.2 Calibrated spring scale Lufkin type 586 or equivalent.

8.3.1.3 Thermometer, -30 degrees F. to 120 degrees F. Lufkin type 583 or equivalent.

8.3.1.4 Vice grip pliers modified with circular jaws and hook to attach calibrated tape.

8.3.1.5 Hand-held magnetic mark locator , rotating staff type with index mark, BenchMark P/N AMS6A001 or equivalent.

8.3.1.6 Yellow or Red marking crayons.

8.3.1.7 Sharp point waterproof black permanent marker.

8.3.1.8 Cleaning wipes or cloth.

8.3.1.9 Calibrated load cell as described in paragraph 8.2.1.1.

8.3.1.10 Cable spooling set-up with capstan, breaks, sheaves and take-up drum configured to allow magnetic marking and checking at 1,000 pounds tension ----and that never allows the cable to have more than 1,000 pounds applied to it between the marking operation and the checking operation.

Spacing of equipment should allow a clear 100 ft. long space for tape measurement.

8.3.2 Procedure

At least two men are required to attach, support tension and read the tape measurements. The preferred method is to check 500 ft. and average the results.

8.3.2.1 Mark the cable at 1,000 pounds tension for 600-700 ft. Be sure that only one capstan is in the system and line tension never exceeds 1,000 pounds onto the take-up drum.

8.3.2.2. Locate the last mark placed on the cable. Clean the cable and mark the general area of the mark with crayon (paragraph 8.3.1.6).

8.3.2.3 Locate the center of the mark carefully using the hand-held mark locator (paragraph 8.3.1.5). These devices are similar to a compass and react to all magnetic fields i.e. the earths field, the marks field and any other magnetic fields from nearby equipment or power lines.

Always locate the center of the mark with the hand-held locator oriented or facing the same direction. The earth's magnetic field will bias the instrument either plus or minus. Never, for example, locate one mark while standing on one side of the cable and another mark from the other side of the cable. An error in locating the apparent center of the marks can be as great as 1/4 inch.

Carefully mark the center with the waterproof marker (paragraph 8.3.1.7).

8.3.2.4 Spool the cable back to the area with the 100ft. space for measuring.

3.2.5. Clamp the vice-grip (paragraph 8.3.1.4.) with the zero end of the tape attached to the hook at the mark located in paragraph 8.3.2.3. Be sure 0 ft. is on the black line of the center of the mark.

8.3.2.6. Locate the next mark on the cable as described in paragraphs 8.3.2.2. and 8.3.2.3.

8.3.2.7. Support the tape along the cable at two places approximately 35 and 70 ft. making sure the tape is straight and not twisted.

8.3.2.8 Confirm that the line tension is 1,000 pounds plus or minus 50 pounds.

8.3.2.9 Attach the spring scale (paragraph 8.3.1.2.) to the tape and tension to 24 pounds.

8.3.2.10 Confirm that 0 feet is still on the mark and that the vice-grip has not slipped.

8.3.2.11 Measure the difference, if any, between the magnetic mark and the 100 ft. mark on the tape with the 6 inch scale provided with the tape (paragraph 8.3.1.1.). Record the results and the ambient temperature.

8.3.2.12 Repeat steps 8.3.2.2. through 8.3.2.11 for a total of 500 ft. measured.

8.3.2.13 For each of the five 100 ft. intervals measured correct the tape reading for temperature effects of the tape. The measuring tape has a coefficient of expansion of 0.08 inches/10 degrees F. and is

calibrated for true measurement at 68 degrees F.

Example –

Interval No. 1			
Temperature	+	90 degrees F.	
Error Measured	+	.250 inches	
Temperature Correction	-	.176 inches	--- $\frac{90-68}{10} \times (.080)$
Actual Error		+ .074 inches	

In this case the tape had expanded due to the 90 degrees F. temperature and was actually reading .176 inch too long.

8.3.2.14 Repeat the temperature corrections for each of the five intervals measured and average the “actual error” figures. The average should be between -0.1 and +0.1inch.

8.4 Summary and Comments

8.4.1 In actual marking practice the cables is almost always spooled onto the logging unit at tensions higher than 1,000 pounds. A cable that has been marked and spooled at typical spooling tension will be very difficult to re-measure the mark intervals.

A typical 7/16 inch multiconductor logging cable will stretch 1 inch in a 100 ft. interval for each 1000 pounds of tension. This does not include the permanent stretch of new cables.

Although logging cable has a stretch coefficient just like a helical spring, logging cable acts very differently. A spring will return to it's original length as soon as the force is removed --- logging cable takes a long, long time to recover.

If a cable is marked at 1,000 pounds and spooled onto a truck at 3,000 pounds, then some line is pulled off to check the marks, it's probable that the marks will be about 100 ft., 2 inches apart. Always give the cable time to relax at a low tension, then pull up to 1,000 pounds and hand strap.

8.4.2 The best way to evaluate marking and mark interval is to confirm the marking equipment/procedure by following the steps of paragraph 8.3.2.1 through paragraph 8.3.2.14.

If the mark interval is acceptable then respool and rig-up to mark and spool at spooling tensions. Mark the complete cable and mark final confirmation of the marking job by carefully checking the last 5 intervals marked which should be spooled onto the logging unit at 1,000 pounds of tension or less as a standard procedure.